

XR 600

Part No.: 8600000

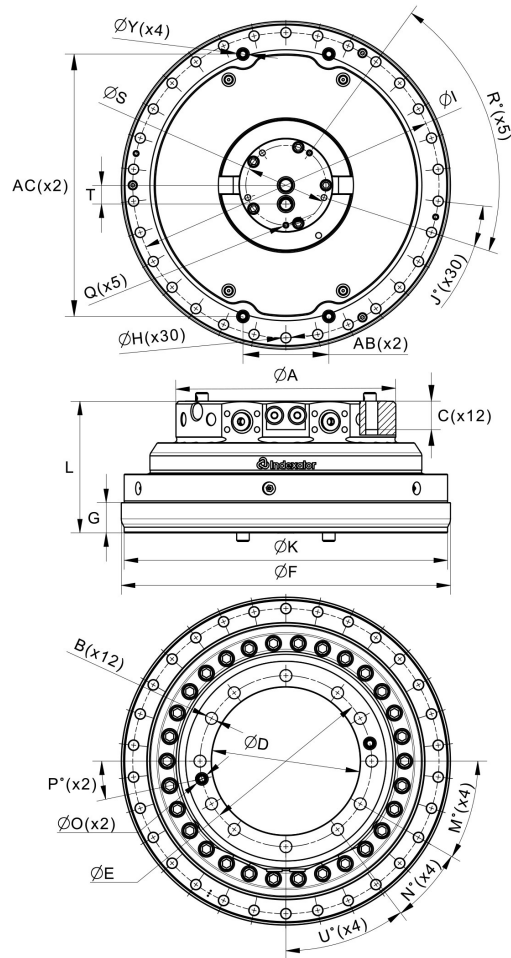
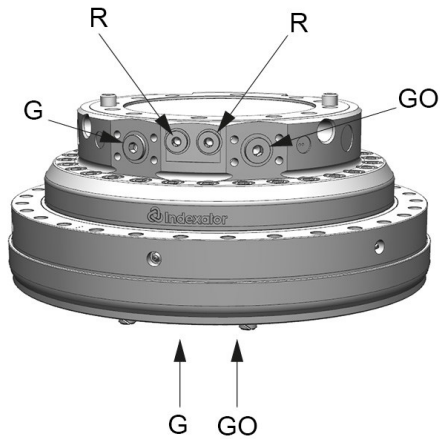

Upper	
G GO: SAE 6000 DN 25	R: G 1/2

A: Ø384 mm	AB: 150 mm	AC: 460 mm	B: M24	C: 53 mm	D: Ø260 mm	E: Ø300 mm	F: Ø575 mm	G: 103 mm	H: Ø17,5 mm	I: Ø535 mm	J: 12°	K: Ø565 mm	L: 231 mm
M: 30°	N: 23°	O: Ø22 mm	P: 12°	Q: M12	R: 72°	S: Ø140 mm	T: 33 mm	U: 37°	Y: Ø22 mm				

264 kg	360°	±850 kN ¹	±300 kN	±200 kN	7000 Nm	40 l/min	25 MPa	35 MPa	35 MPa	35 MPa

¹ Max axial load static indicate theoretical max load for hanging applications without accelerations.

Oil distributor ordered separately

Pressure limiting valves fitted.