

OPERATION, MAINTENANCE AND SPARE PARTS MANUAL

HYDRAULIC FEEDER HF260-EM + NO STRESS W150

**READ THIS OPERATION AND MAINTENANCE MANUAL CAREFULLY
BEFORE USING THE MACHINE**



Farmi Forest Corporation
Ahmolantie 6
FIN-74510 Iisalmi, Finland
Tel. +358 (0)17 83 241
Fax. +358 (0)17 8324 372
www.farmiforest.fi

HF260-EM

TABLE OF CONTENTS

INTRODUCTION	4
PRODUCT WARRANTY	4
CUSTOMER FEEDBACK	4
WARNING SYMBOLS IN THIS MANUAL	4
GENERAL SAFETY INSTRUCTIONS	5
STICKERS AND PLATES	9
PRESENTATION	10
TECHNICAL DATA	11
LIFTING	12
MOUNTING	12
CONTROLS	15
OPERATION	16
ADJUSTING THE FEED SPEED	16
MAINTENANCE	17
SETUP GUIDE W150 FOR FARMI FOREST CHIPPER	19
MACHINE SETUP	20
ALARMS	25
HF260 ELECTRICS	28
NO STRESS FARMI 260	28
03485100 FEED ROLLER BOTTOM	29
03489150 FRAME, ROLLER, ROLLER'S SWING	30
03489210 FEED CHUTE HF260-EM	32
200003108 FEED CHUTE EXTENSION	34
03489160 HYDRAULICS	36
HYDRAULICS CIRCUIT DIAGRAM	38
56072119 DIRECTIONAL CONTROL VALVE VICKERS	39
PRODUCT REGISTRATION FORM	42

When ordering spare parts, please indicate machines type from the machine plate, spare parts order number, description and quantity required.

Example. HF260-EM, 43484180, Upper feed roller, 1 pc

HF260-EM

INTRODUCTION

This manual includes the information and maintenance instructions required for operating the machine in the optimal manner.

Although you have experience in using this kind of machinery, read the operation and maintenance instructions carefully since they include information enabling efficient and safe operation. Regular maintenance is the best way to guarantee the efficient and economical performance of the machine.



Each and every operator must read, understand, and follow all safety instructions and procedures.

PRODUCT WARRANTY

Farmi provides a 12-months warranty on all Farmi products.

Register on our home page (www.farmiforest.fi) under FeedBack ("Product Registration" form) within 30 days after the receipt of the product to get full product warranty and additional information on your product. If it is not possible for you to register via internet, please register as follows: Complete the registration form on the last pages of this manual and return it to us within 30 days after the receipt of the product.

CUSTOMER FEEDBACK

We are happy to receive your opinions and suggestions for improvements by mail, fax or e-mail. All implemented suggestions for improvements will be rewarded.

WARNING SYMBOLS IN THIS MANUAL



- imminent danger which could cause serious personal injury or death



- danger which could cause personal injury



- conditions or misuse that could damage equipment or machinery
- reminders, such as for performing checks or carrying out maintenance or repair procedures

HF260-EM

GENERAL SAFETY INSTRUCTIONS

These safety instructions are meant for the owners of FARMI equipment, as well as those who operate, service or repair it.

The instructions help with:

- using the machine safely, appropriately and effectively.
- identifying, avoiding and preventing potentially dangerous situations.

The manufacturer supplies an instruction manual, which must always be available at the place of operation of the machine. Each user must read the safety, maintenance and operating instructions before operating the machine, and comply with these instructions at all times.



Ensure that every operator of the machine is familiar with the content of the instruction manual and situation-specific safety instructions, and has been suitably trained before operating the machine.

The machine complies with technical requirements and applicable safety regulations. However, incorrect use, maintenance or repair of the machine may cause risks.

In addition to the instruction manual, remember to comply with regulations of the local occupational health and safety authorities, and with your country's laws and decrees.

The manufacturer is not liable for damages caused by:

- incorrect, negligent or inappropriate use of the product.
- non-original spare parts.
- normal wear and tear.
- misuse caused by an untrained person's improper actions.
- alterations made without the manufacturer's permission.



Written authorization must be requested from the manufacturer for any alterations to the machine.

STARTING

- Familiarize yourself thoroughly with the use, operation and controls of the machine and its equipment before starting.
- Familiarize yourself with the capacities and limitations of the machine and its equipment.
- Do not use the machine unless you are completely familiar with its operation.
- Be aware of the machine's danger zones.
- During operation, prevent bystanders from entering the danger zone.
- Ensure that each operator has the necessary safety equipment, such as a helmet, safety goggles, work safety boots and suitable protective clothing.
- Never wear loose clothing around moving parts. Protect long hair!
- Ensure that work is carried out according to the stipulations of applicable occupational health and safety legislation.
- Before starting up or using the machine, ensure that it cannot cause a risk to other people or property.
- Perform a safety check on the machine before every use. If you observe any faults or deficiencies, repair the machine immediately.
- Before operating the machine, ensure that there are no foreign articles in it.
- Place the machine on a hard, level surface for operation. In the winter avoid working in slippery areas.
- Before mounting and using the machine, check the PTO drive shaft for correct condition and attachment.
- Never use a faulty or deficient machine.

HF260-EM

TRANSPORT

- Before driving with the machine, ensure the safe mounting of the machine. Make sure that the journals are seating correctly and that the pins are tight. Check the tension of the lower link stabilizers.
- Before driving with the machine, make sure that the required lamps and reflectors as well as the slow moving vehicle sign are attached correctly. Moreover, the lamps should be checked for correct functioning.
- Before driving with the attached machine, make sure that the hydraulic unit of the machine is depressurized (unless otherwise instructed in the operating instructions).
- When driving on public roads, always observe the valid traffic regulations. The travel speed must be adapted to the specific conditions.
- When driving, please take into consideration the additional mass resulting from the machine's weight. It may affect the reactions, the steerability and the braking function of the tractor.
- Please note that the machine rear sways when turning.
- Pay attention to the machine's height near bridges or other height restricting objects.
- When backing off, the machine may obstruct the rear view. Exercise extreme caution. If necessary, ask a flagman to help you; he can indicate the required distances.
- It is prohibited for other people to ride on the machine.

- Never insert any body part into the machine with the engine running.
- If any faults arise that may jeopardize occupational safety, turn off the machine.
- During operation, the machine's operator is responsible for safety in the whole work area. Work may not be carried out in the presence of any factors that jeopardize occupational safety.
- Exercise extreme caution when hitching / unhitching the machine from a tractor/trailer.



The machine's operator must have constant, unobstructed visibility of the work area. If this is not possible, the operator must work with an assistant.

OPERATION



Many occupational accidents take place in abnormal circumstances. Therefore it is important to take into account all the possible circumstances that may arise during operation of the machine.

- Depending on the machine's type, it will have diverse safety devices and protectors. These are meant to protect the machine and its operator, and they must never be removed or altered. Never start up or use the machine without all the safety devices and protectors in place. Also check the universal joint's safety equipment and joints.

- Look out for moving parts when the machine is in operation.
- Secure the machine against unauthorized and accidental operation (e.g. moving when parked) whenever it is left unattended.
- Never leave the machine running unattended.
- Avoid causing fast, stroke-like loading.
- Never exceed the given operating values.
- All safety and warning signs on and in the machine must be legible and intact.
- The machine may not be operated by persons who are unwell or under the influence of drugs or alcohol.

MAINTENANCE

- The machine may only be serviced and repaired by professionals.
- Electrical and hydraulic faults may only be repaired by authorized professionals.
- In cases requiring welding, contact the manufacturer.
- Turn off the tractor engine and disconnect the universal joint before beginning service or maintenance actions.
- Before any maintenance work, turn the main power switch of the tractor to OFF.
- Ensure that there is no pressure in the hydraulic system.
- Take out the key from the tractor's ignition for the duration of the servicing or maintenance. Check that the power is off from the machine you are working on.

HF260-EM

- When servicing the machine, place it on a level surface and ensure that it cannot be moved.
- Observe the service intervals and annual safety inspections.
- All spare parts and equipment must fulfill the manufacturer's requirements. This can be guaranteed by using original parts.
- Put all safety devices back into place immediately once servicing or maintenance is complete.



When lifting the machine, check that the lifting/hoisting equipment is in perfect working order. Check the weight of the machine before lifting it. Choose lifting trajectories so that they do not cause any danger.

Many countries have specific legislation on lifting, hoisting cables and hoists. Always comply with local safety regulations.

OILS AND LUBRICATION

- Always use the oil types recommended by the manufacturer. Other types of oil may cause faults or improper operation of the equipment, which could lead to serious damage to people or property.
- Never mix different liquids or oils.
- Always follow the manufacturer's lubrication instructions.
- Use control equipment carefully until the hydraulic oil has had time to reach its operating temperature.

SAFETY INSTRUCTIONS FOR HYDRAULIC CIRCUITS

1. Work on hydraulic equipment may only be carried out by professional hydraulic engineers.
2. Be cautious when using the equipment in cold conditions.
3. Check the machine for leaks. Do not use the machine if there is a leak from any system. Check all hydraulic hoses – particularly those which are bent during use – and replace any that are in poor condition or have leaks. Ensure that all joints are tight and that the lines are not damaged. Check that all protective caps and filler caps are closed properly. Check the hose sheathing for damage.
4. Check that all hose connectors, lengths and qualities comply with applicable requirements. When replacing or repairing hoses, use original parts or hoses and connectors recommended by the manufacturer. Check particularly that the pressure classes of the hoses and connectors are suitable to the operating pressure levels.
5. Check that all safety devices such as pressure relief valves, etc., are in place and work properly. Familiarize yourself with their use. Safety systems may never be bypassed.
6. Check the main hydraulic parts daily, and always after a fault. Replace any damaged parts immediately.
7. If a component is damaged, clean it before repairing it. Do not use solvents when cleaning parts.
8. Do not attempt to carry out repairs that you are not fully familiar with.
9. Never carry out repairs of the hydraulic circuit when the system is pressurized. When pressurized, the oil spray can penetrate the skin and cause mortal danger.
10. Never work below a device or component that is only being held up by hydraulics. Use separate supports when carrying out maintenance or repairs. Do not disconnect cylinders or their valves until the machine is well supported.
11. Most hydraulic oils do not evaporate easily. Risk factors include hot oil, spills and oil mist (pressurized).
12. If oil gets into your eyes, rinse with plenty of water and contact a doctor.
13. Avoid prolonged or repeated contact with your skin.
14. If sprays or contact with the skin cannot be avoided, use protective gloves, goggles and clothing as necessary. Do not use oily clothing.

HF260-EM

15. Avoid discharging hydraulic oil into the environment, as it can pollute waterways and the groundwater. If biodegradable oil is to be used, please contact the manufacturer beforehand and have the suitability of your equipment for the operation with biodegradable oil confirmed by him before such oil is used.
16. Store the oil in sealed containers provided by the manufacturer. Try to transfer the oil directly from its container into the tank.
17. If the oil must be passed through other containers, ensure that they are completely clean. Caps, funnels, sieves and filling holes must also be clean.
18. Never store oil outdoors, as water could condense in it.
19. Always dispose of oil in a suitable container, never into the environment!

HF260-EM

STICKERS AND PLATES

These stickers and plates must be found from feeder. Missing ones must be replaced immediately.

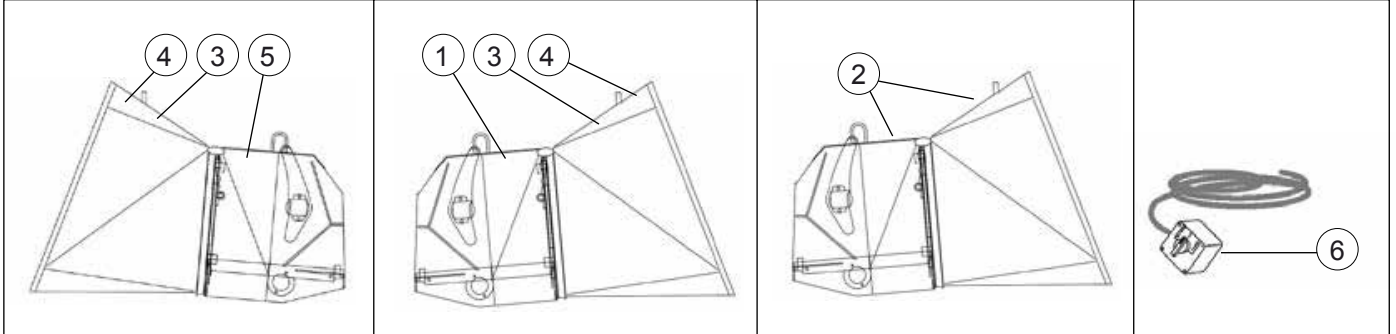

1. Manufacturer (40605214)

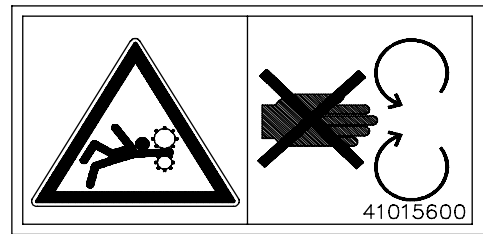

4. Stay away from revolving parts. (41015600)

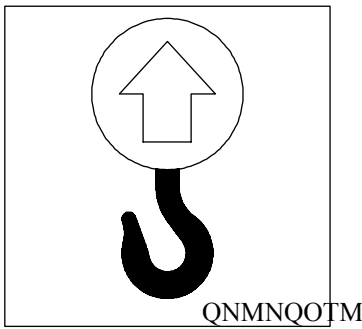

2. Lifting point (41014170)

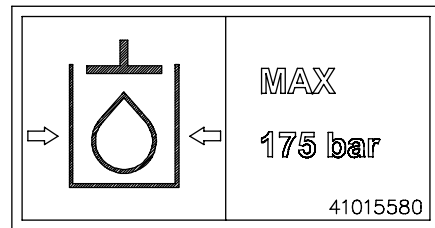

5. MAXIMUM Hydraulic pressure 175 bar (41015580).

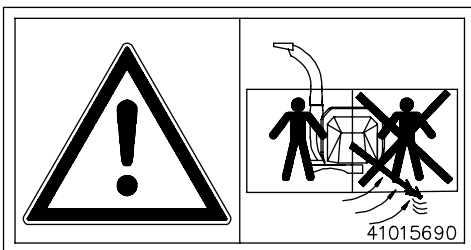

3. Note! (41015690)
Stand on the left side of feeder.

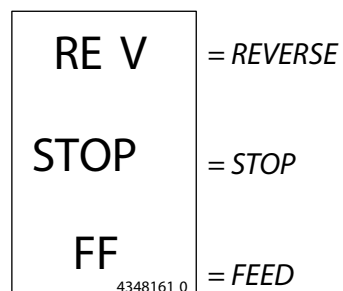

6. Control direction sticker shows the control panel switch functions for controlling the feed rollers (43481610)

HF260-EM

PRESENTATION

The HF260-EM hydraulic feeder makes it easier to handle hard-to-feed materials. The chips produced are of high quality since the feed speed remains constant and sufficient even when the knives and anvils become dull.

The feeder can be connected to the tractor's hydraulic system or to the HD11 independent hydraulic unit.

The feeder can be easily installed to replace a mechanical hopper.

The optional "No stress" device limits feed at low speeds, ensuring that

- homogeneous chips are produced
- the engine does not stall unnecessarily
- a lower-output engine can be used
- higher output is yielded.

MAIN COMPONENTS

1. STOP HANDLE
2. DIRECTIONAL CONTROL VALVE
3. FLOW-REGULATING VALVE
4. ELECTRIC VALVE / SOLENOID VALVE
5. HYDRAULIC MOTORS
6. FEED ROLLERS
7. FRAME
8. FEED CHUTE
9. NO STRESS DEVICE (OPTION)
10. ELECTRIC SYSTEM
11. MANUAL CONTROL SWITCH
12. EMERGENCY STOP SWITCH
13. EMERGENCY STOP BAR
14. CONTROL PANEL / DISPLAY

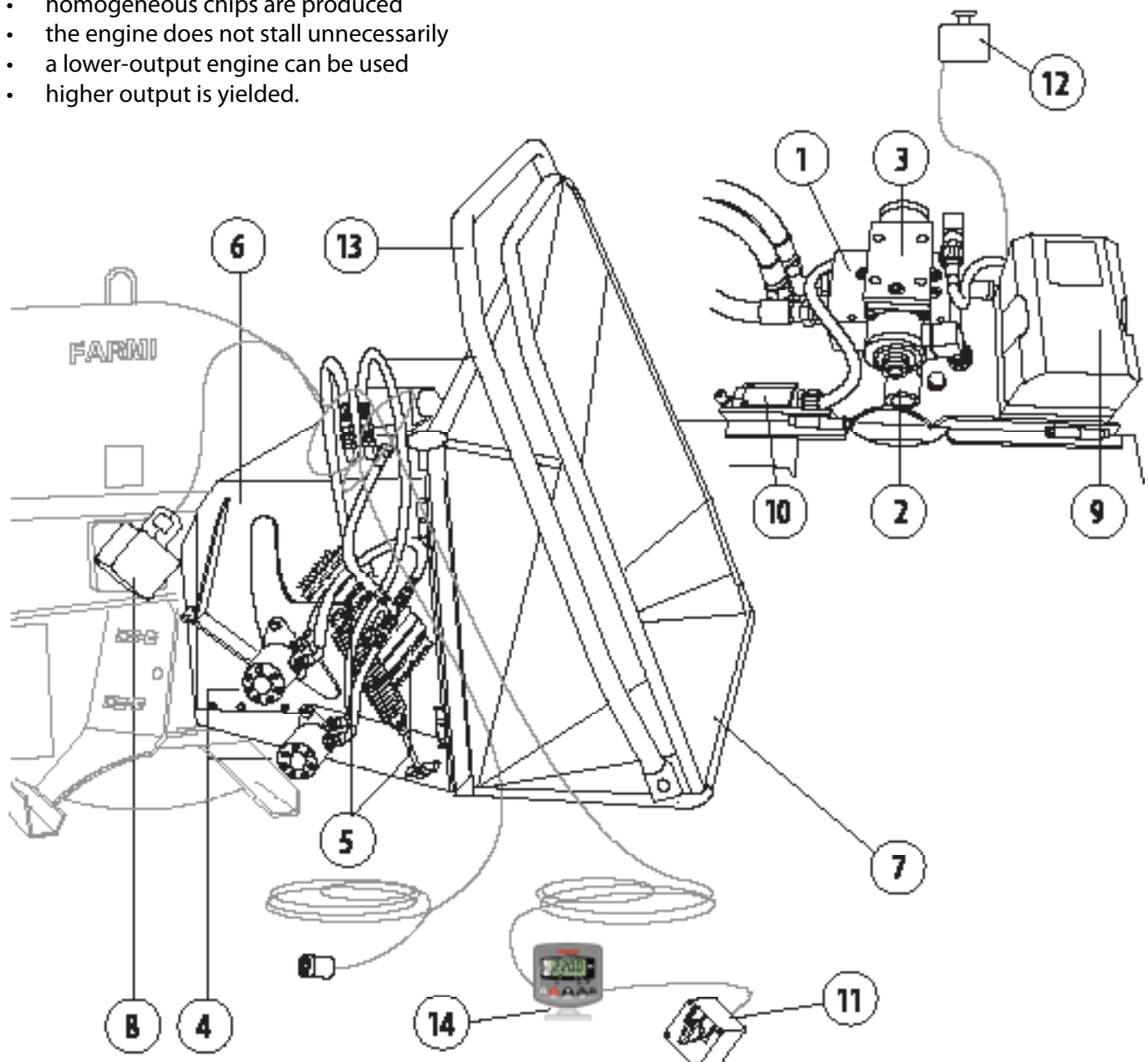
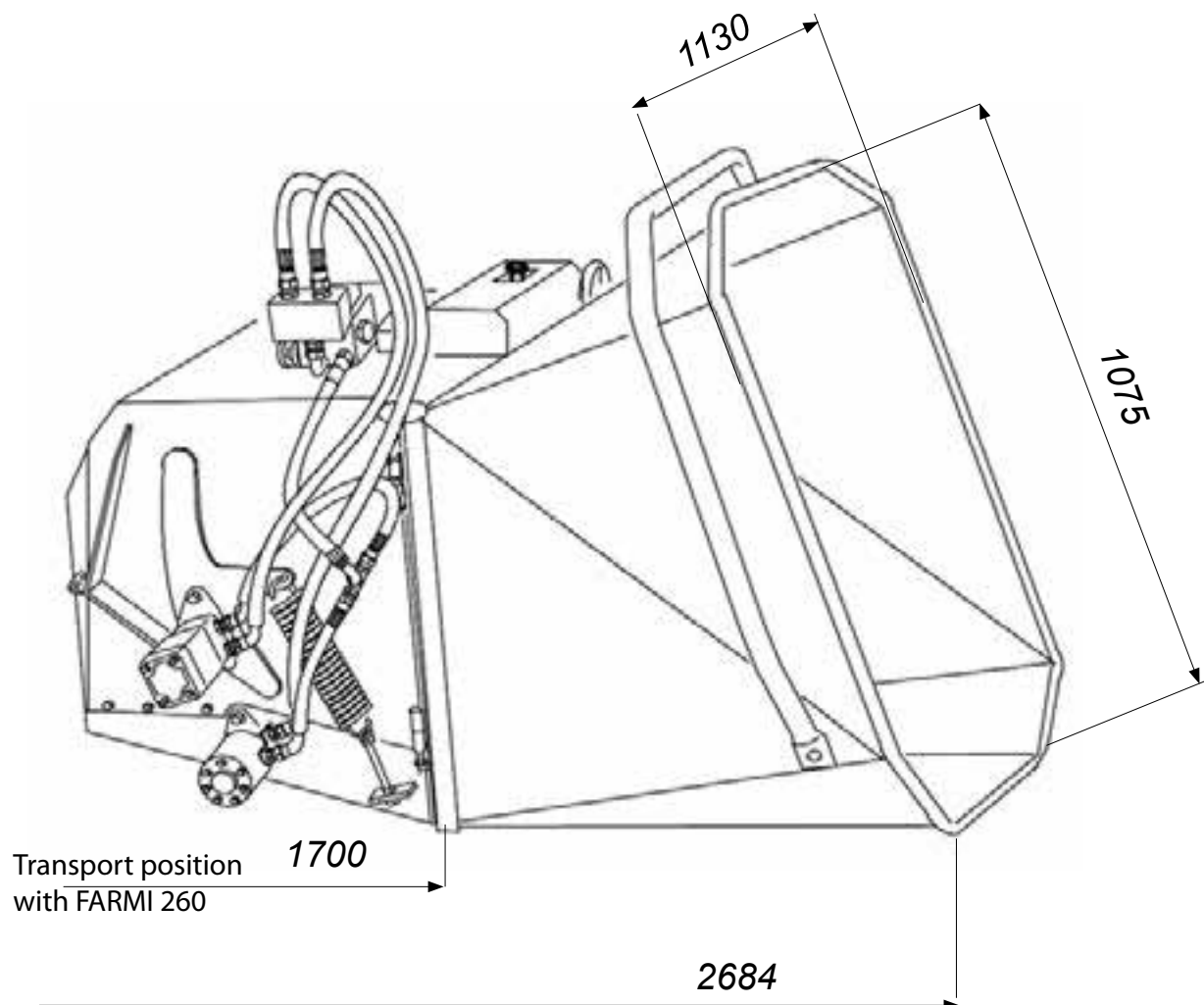

Fig 1. Main components

HF260-EM

TECHNICAL DATA	HF260EM
Feed roller	ø280 mm + ø170 mm
Max. tree diameter	ø260 mm
Hydraulic motors	250 cm ³ + 400 cm ³
Oil demand, P.T.O speed chip 20 mm, 540 rpm chip 20 mm, 1000 rpm	20 l/min 37,2 l/min
Max. working pressure	175 bar
Weight	290 kg

DIMENSIONS



HF260-EM

LIFTING



Lifting points for each machine are marked with hook symbols.

Lift only by using the proper type of lifting device, and ensure that it has an appropriate lifting capacity.

Check the lifting slings, cables, and chains regularly.

Ensure that you know the weight of the load to be lifted and never exceed the lifting capacity stated by the manufacturer of the lifting device.

Select routes for lifting so that the load is not transported over people or a location where people might be.

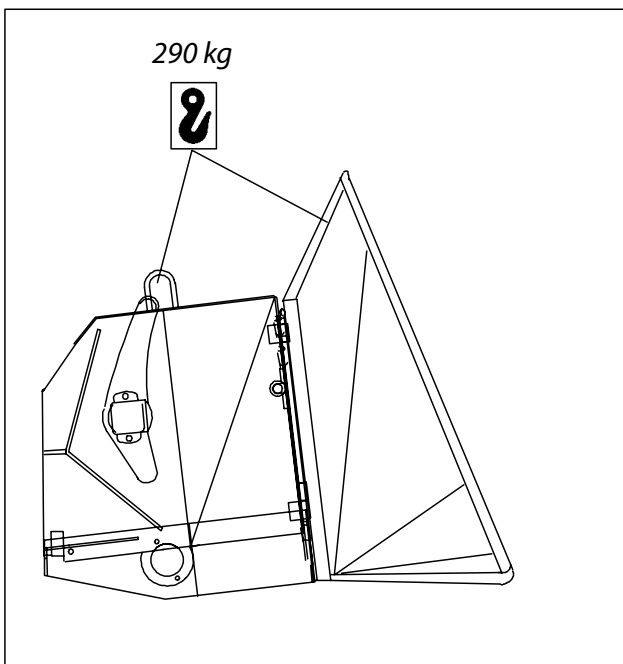

Fig. 3. Lifting points

MOUNTING

1. The hydraulic feeder and mechanical feeders include adaptor pieces that are installed between the chipper and feeder. The adaptor pieces are installed so that the two guide pins located at the bottom section of the feed opening go through the holes in the adaptor piece and secure the piece. See Fig. 4.
2. Attach the feeder frame to the chipper pins and lock bolts. Fig. 5.

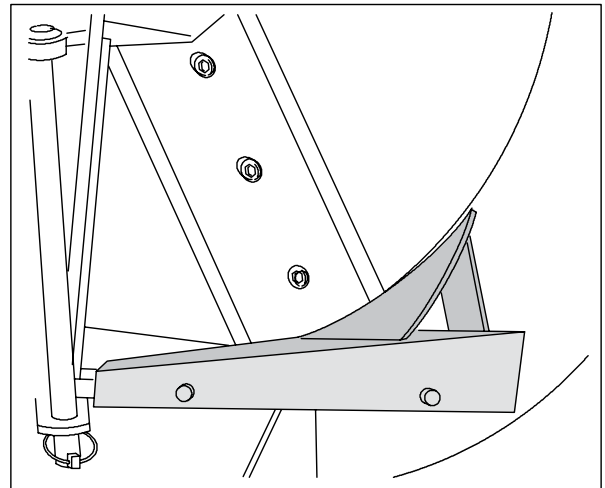

Fig. 4. Installing the adaptor piece

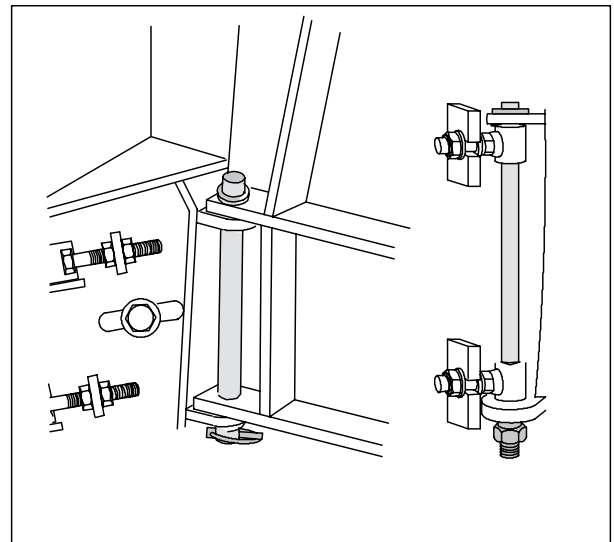

Fig. 5. Mounting the feeder on the chipper

HF260-EM

3. Attach the feed chute extension to the feeder with two M10x150 bolts and lock nuts. Fig 6a.
4. Attach the feed chute to the feed chute extension with two M10x150 bolts and lock nuts. Fig. 6b.
5. Lock the chute in the operating position. Fig. 7.
6. Connect the hydraulic hoses. Connect the pressure hose (P on the valve) to the pressure connector of the tractor's hydraulic system. The maximum operating pressure is 175 bar. Connect the return hose (T) to the return connector of the double-acting valve, or preferably directly to the tank. Fig. 8.

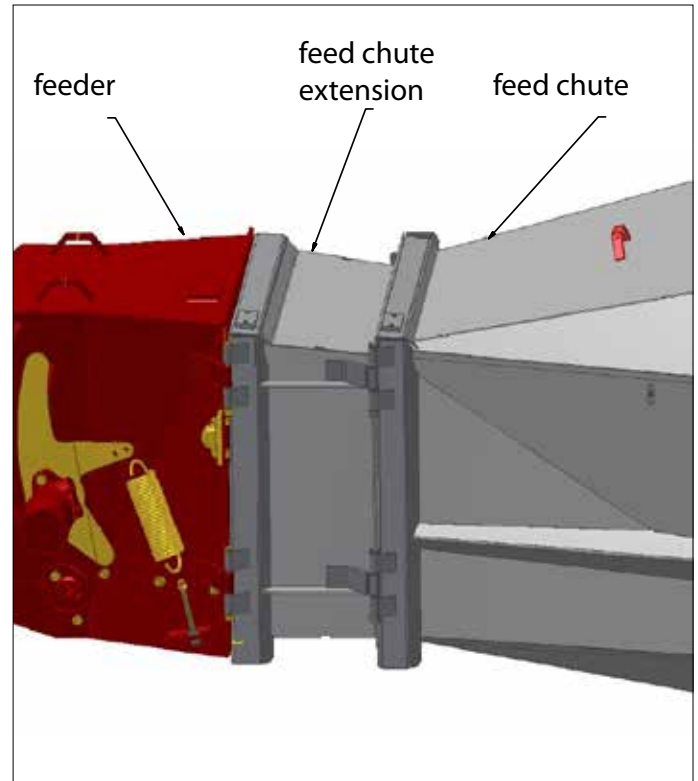

Fig 6a.

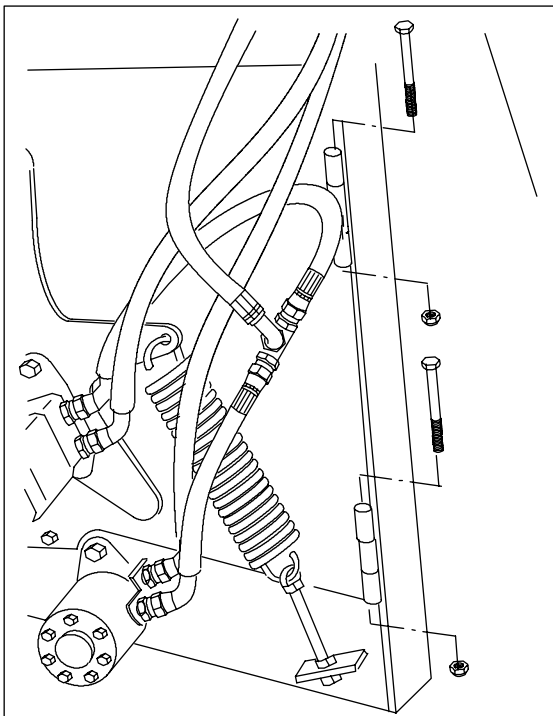

Fig. 6b. Installing the hinge bolts

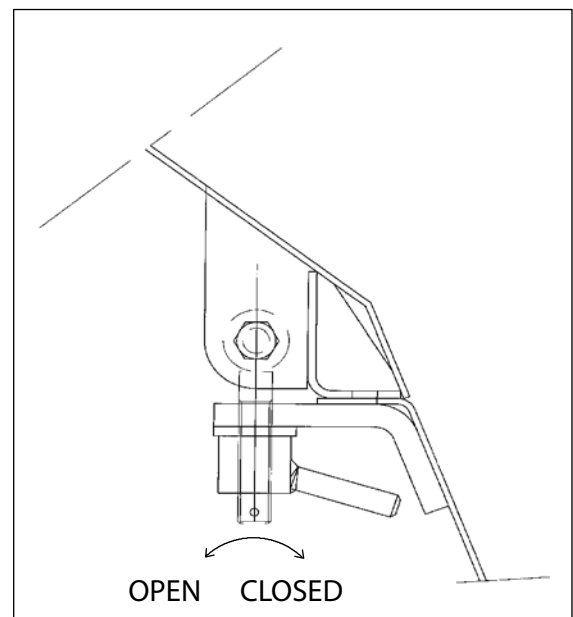

Fig. 7. Locking the feed chute in the operating position

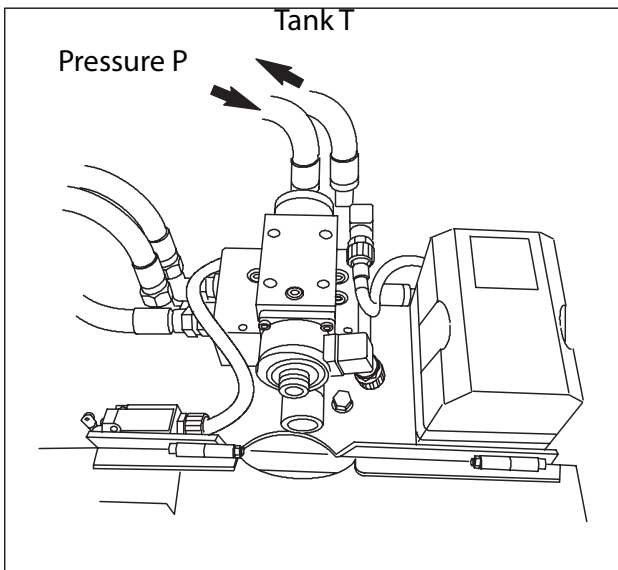

Fig. 8. Connecting the hydraulics

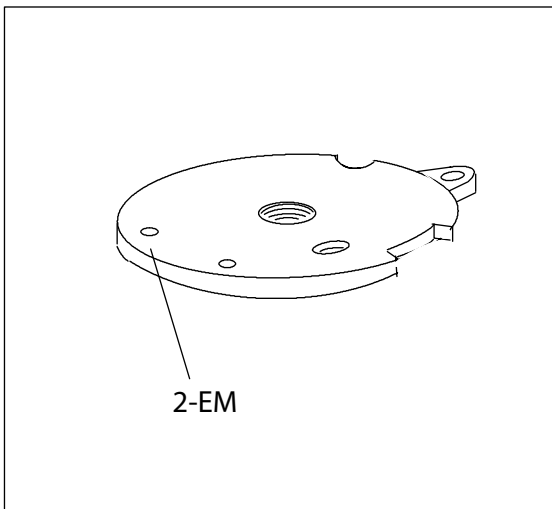

Fig. 9. Attaching the stop handle

HF260-EM

CONTROLS

The feeder is operated from the remote control panel. The feed rollers can also be stopped with the stop handle. See Fig. 10.- 13.

1. STOPPING = STOP

The feed rollers do not rotate.

2. FEED = FF

The feed rollers start to rotate inwards and trees can be fed in.

3. REVERSE = REV

The feed rollers start to rotate outward and the tree can be removed from the feed rollers. The operation switch returns automatically to the STOP position.

4. STOPPING WITH THE STOP HANDLE

The feed rollers are stopped. Reset by turning the operation switch on the control panel to the STOP position before again selecting the feed direction.

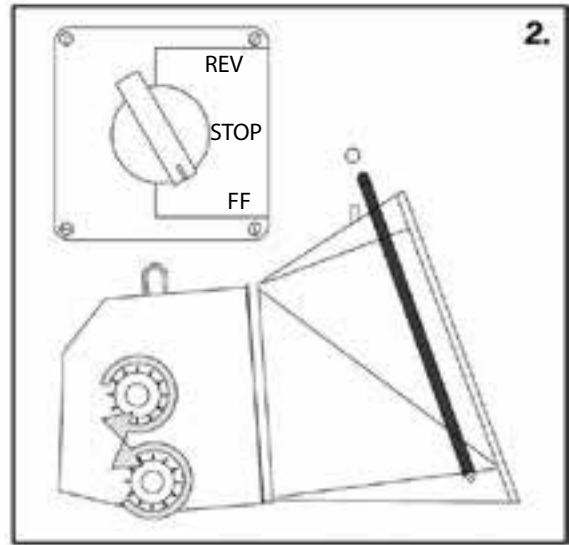

Fig. 11. Feed

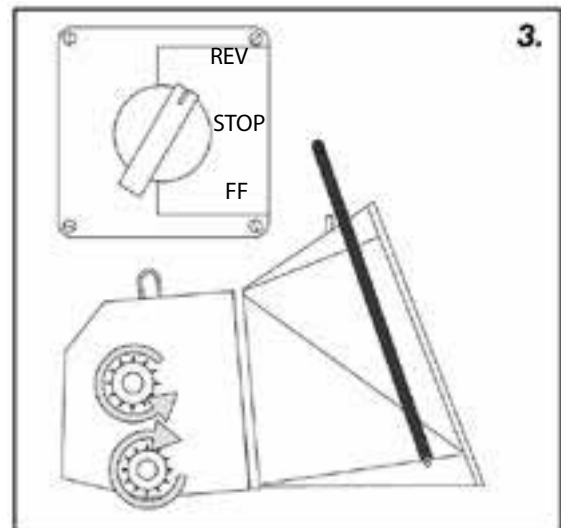

Fig. 12. Reverse

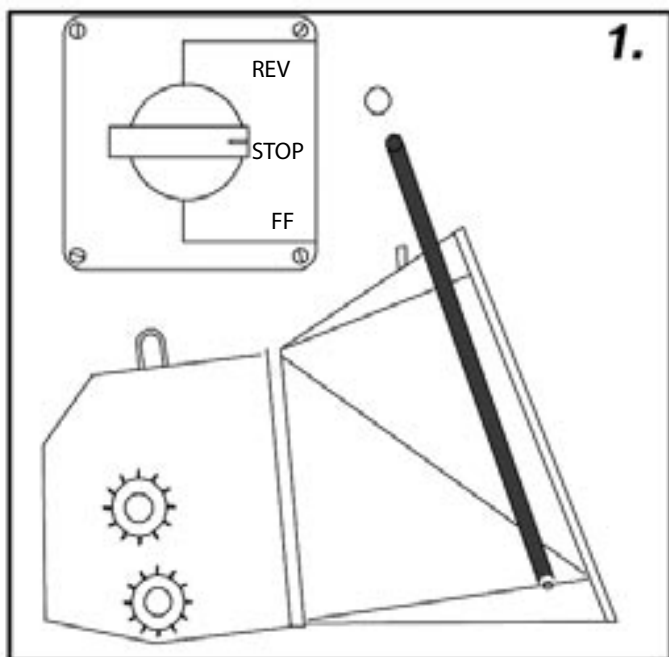

Fig. 10. Stopping the feed

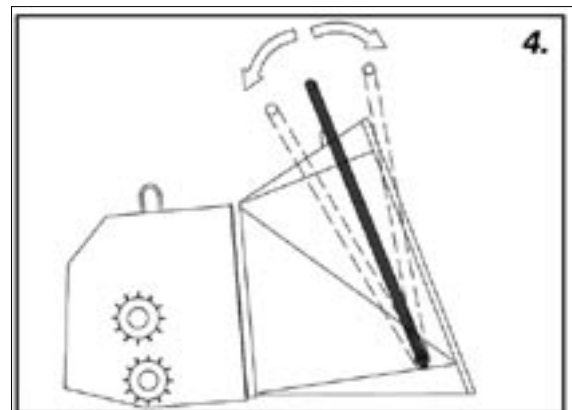

Fig. 13. Stopping the feed with the stop handle

HF260-EM

OPERATION

1. Ensure that the feed chute is empty. Connect the tractor hydraulics and the chipper's electric plug.
 2. Connect the tractor's PTO with raising the switch carefully. Otherwise the fluted shaft may get damaged.
 3. Turn the operation switch on the control panel to the FF (feed) position.
 4. Before feeding in the material to be chipped, ensure that the material is free from nails, stones, etc.
 5. Feed the trees into the chute with a crane. Release the tree from the grapple immediately when the feed rollers start to pull it inside.
 6. If necessary, adjust the feed roller speed according to section Adjusting the feed speed.
- When chipping large trees with a low-output tractor, stop the feed before the disk speed decreases notably by turning the operation switch to the STOP position. After the speed increases, continue feeding by turning the switch to the FF (feed) position.
 - If you need to remove the tree from the feed chute in the middle of chipping, turn the operation switch to the REV (reverse) position and hold until the feed roller releases the tree.
 - The feed rollers can be also be stopped with the stop handle. After stopping, the operation switch on the control panel must be turned to the STOP position before the rollers start to rotate.



Oil is heated when it flows through the hydraulic pump, motor, and valves. Notable heating can occur if the tractor features a small hydraulic oil tank.

To prevent oil from overheating, check the oil temperature every 30 minutes. If the oil overheats, allow it to cool by stopping the chipping.

ADJUSTING THE FEED SPEED



Do not set the feed rate at the same time when feeding the timber, the valve may get damaged. It is recommended to set the feed rate while the rollers run unloaded and test the speed thereafter.

Use the flow-regulating valve to adjust the feed roller speed to correspond to the disk speed.

- The feed roller speed is increased or decreased by turning the knob counter-clockwise or clockwise, respectively. See Fig. 14.
- The speed is correct when the trees do not push against the disk and the feed roller teeth do not slow down the feed.

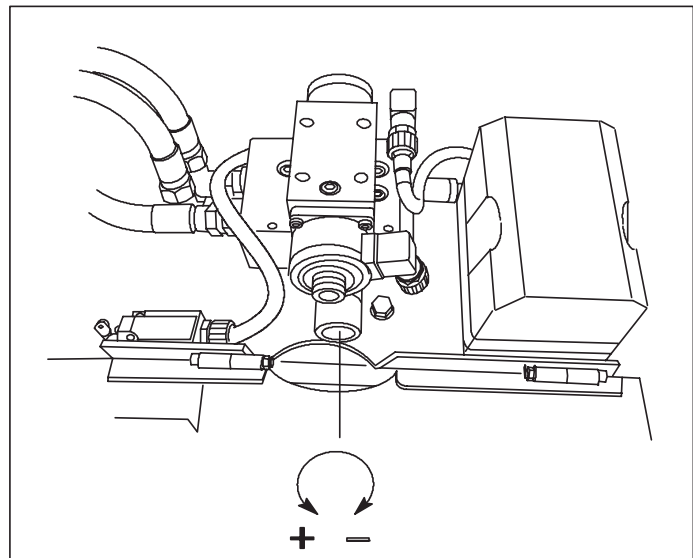

Fig. 14. Adjusting the feed roller speed

Feed roller speed in relation to chip length	
Chip length, mm	Upper feed roller speed at the PTO speed of 540 rpm
7	8,6
15	17,4
22	27

MAINTENANCE

- The feed roller bearings are sealed and do not require periodic maintenance.
- Lubricate the roller bracket shaft after every 20 operating hours. See fig. 15.
- Lubricate the rotor bearings after every 50 operating hours. See fig. 16.
- Check and tighten loose bolts at regular intervals.
- Check the condition of the hydraulic hoses and regularly inspect the connections for leaks.
- Be sure to use only clean oil in the hydraulic system. The presence of impurities in oil damages the valves and hydraulic motors.

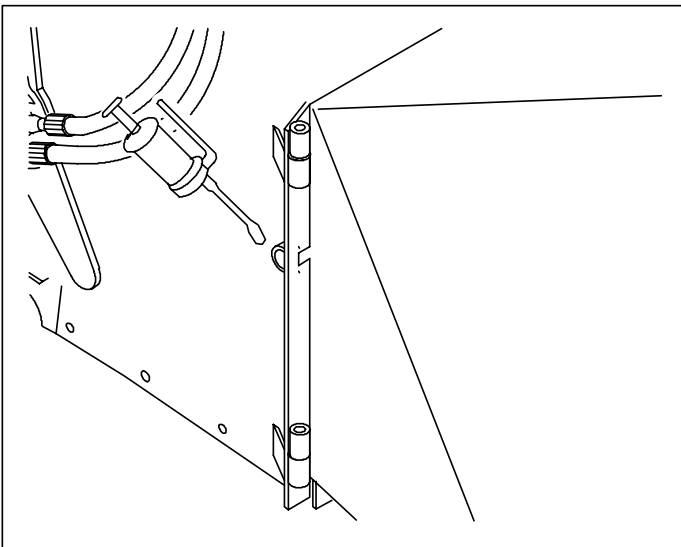

Fig. 15. Lubricating the feed roller bracket shaft

HF260-EM

LED ON = SPACING CORRECT
LED NOT ON = MOVE SENSOR CLOSER

The programming button is on the remote control panel.

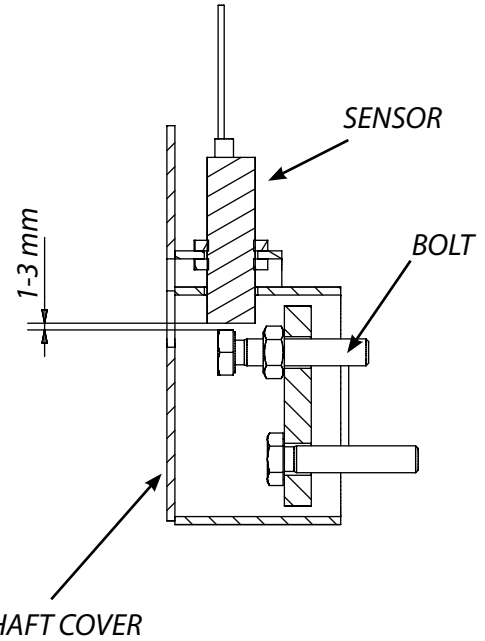
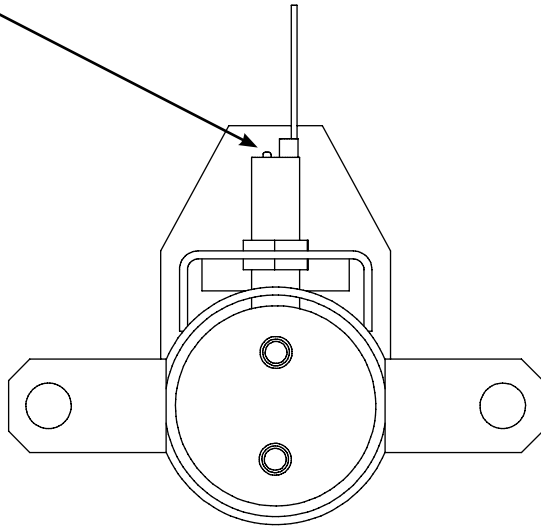
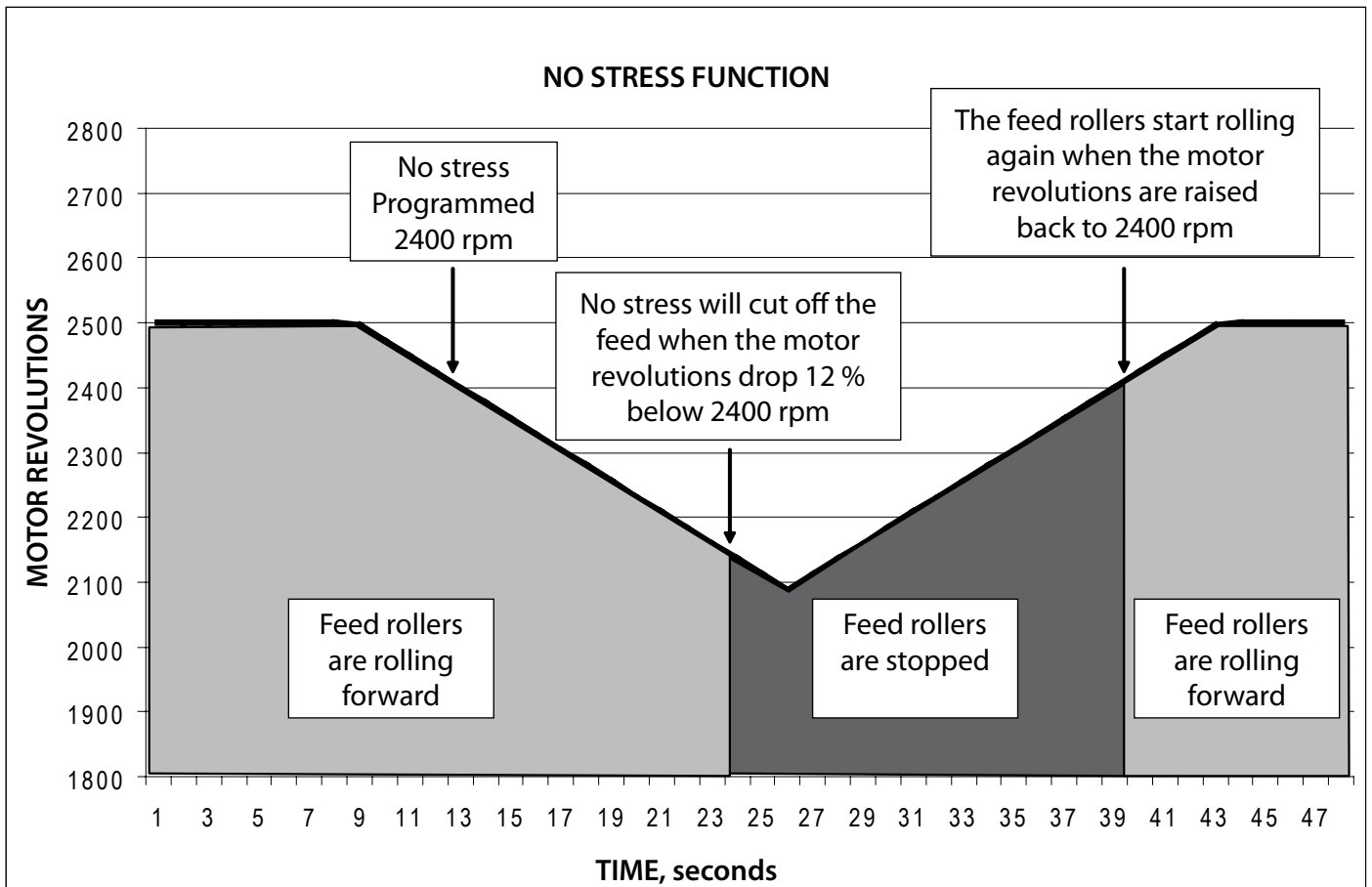

Fig 17. No Stress adjustment



HF260-EM

SETUP GUIDE W150 FOR FARMI FOREST CHIPPER

OVERVIEW

The instrument monitors the chipper RPM and 'No Stress' function will engage and disengage the feed rollers at a programmable threshold.

DISPLAY FUNCTIONS

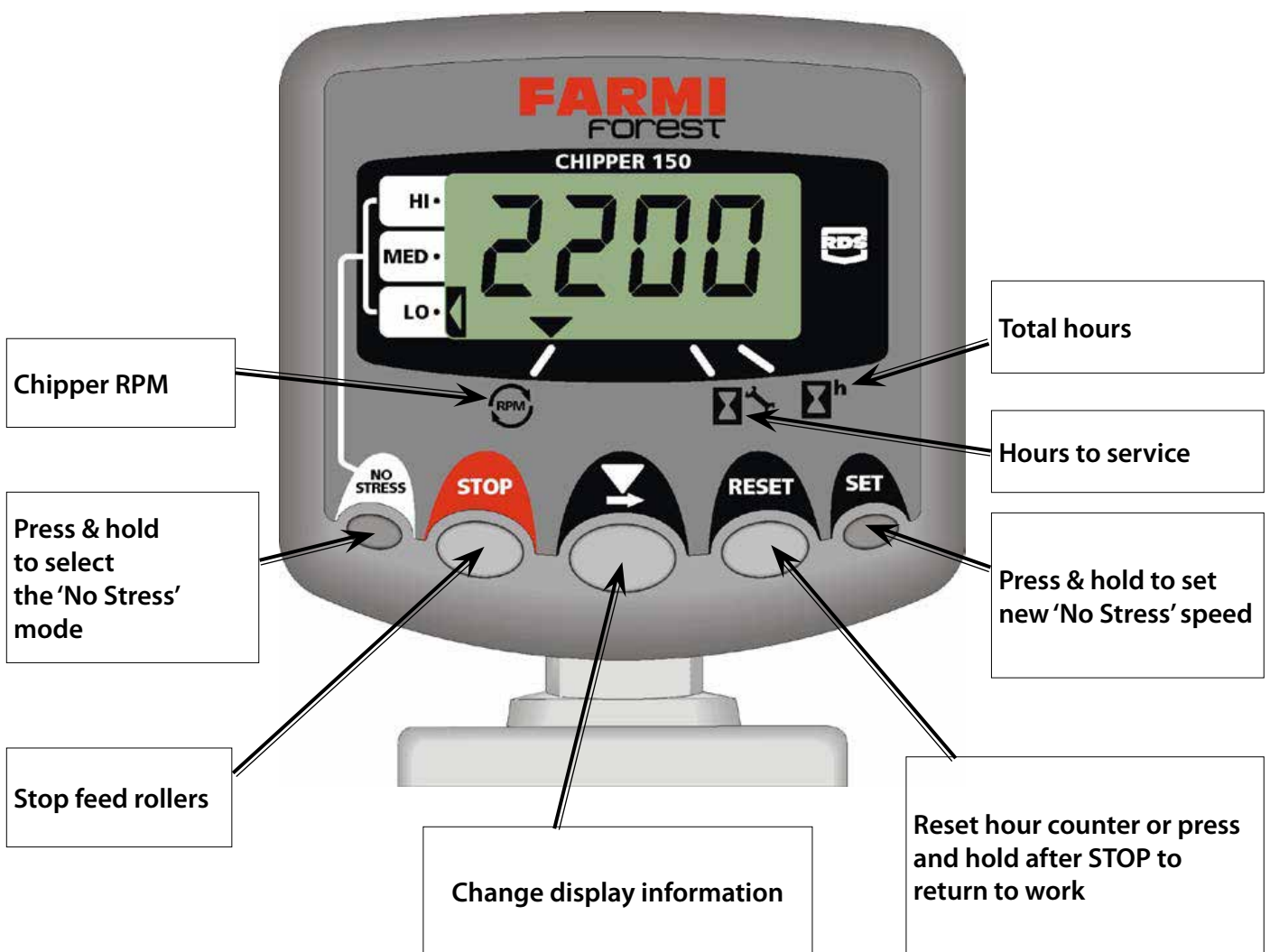

- Channel 2 – Chipper RPM
Shows the current chipper speed.
- Channel 5 – Hours to machine service
Hour timer counts down to show when the next machine service is due.
- Channel 6 – Total machine hours
Total hours that the machine has worked.

HF260-EM

MACHINE SETUP

NO STRESS SPEED

For 'LO' the No Stress speed is currently set to 480 rpm, if this needs changing it can be programmed in 2 different ways:

1. Press and hold NO STRESS button and connect power to the instrument. The display will show CAL5 and the NO STRESS button can now be released. The first number shown is the 'LO' no-stress speed (default = 480 rpm). This is the RPM at which the feed rollers will stop rotating.

OR

2. When the chipper is rotating at the desired speed, press and hold SET for 5 seconds. Keep the button pressed until the number flashes and the instrument beeps and shows 'done'. This speed is now stored as the No Stress speed.

The MED and HI 'no-stress' speeds can also be set in programming mode 5 or by using the SET button when the chipper is rotating at the required No Stress speed.

When the speed is 0 the existing No Stress speed can be seen by pressing and holding the SET button.

NO STRESS OPERATION

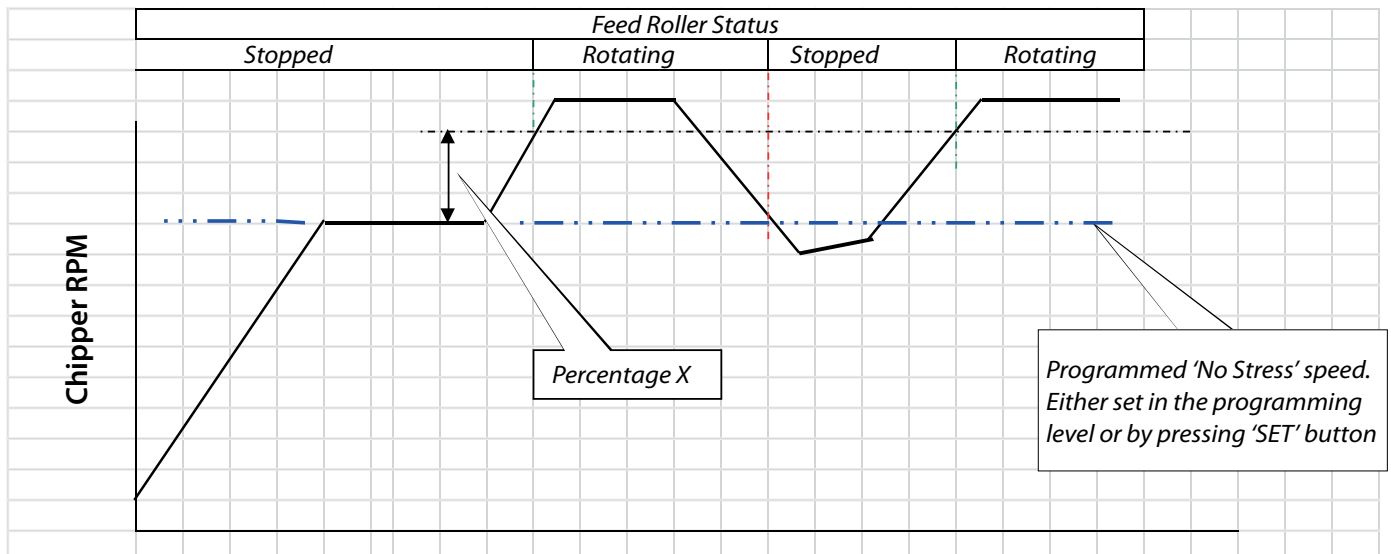

HF260-EM

Once the chipper speed has dropped below the no-stress speed, it must return to a certain RPM before the feed rolls are engaged again. This is expressed as a percentage of the no-stress speed. Currently set to 11% e.g if no-stress speed is 480 rpm, feed rolls will stop when chipper speed is <480 rpm and will only start to rotate again when speed reaches $480 + 11\% = 530$ rpm.

NO STRESS PERCENTAGE 'X'

To change the resume percentage 'X', press and hold STOP button for 5 seconds whilst on the chipper rpm channel. With STOP still pressed, pressing the middle button will increase the resume percentage. When the correct number is displayed, release all buttons.

FEED ROLLER REVERSE

When the feed rollers stop there will be delay (Feed rollers reverse delay) and then the rollers will reverse for 'Feed rollers reverse duration'.

By setting the 'Feed rollers reverse delay' to 0.0 seconds, the reverse function is turned off.

The reverse delay and duration can be adjusted in programming mode 3. To enter the programming mode press and hold the RESET button while turning the instrument on, keep the RESET button pressed for a further 10 seconds and the display will show CAL 3. Press the RESET button twice more and the display will show the reverse delay. This can be programmed by pressing and holding the middle button.

Pressing RESET again moves to the 'Feed roller duration' setting and this can be programmed in the same manner.

HF260-EM

OPERATION

When the speed is greater than the 'No-Stress' speed + resume percentage then operation of the feed rollers is allowed.

Switch box operation is as follows:



Turn to operate reverse. Display shows 'rr' when held.

Turn to operate forward. Turn & hold for greater than 1 seconds to operate forward permanently Display shows 'fr' when held.

For the feed rollers forward to be 'latched on' the switch must be held in the forward position for greater than 3 seconds.

The 'latching' time period can be set in programming mode 4. To enter the programming mode press and hold the SET button while turning the instrument on, keep the SET button pressed for a further 10 seconds and the display will show CAL 4. Press the SET button twice more and the display will show the latching time. This can be changed by pressing and holding the middle button. The time period can be set from 1 – 9 seconds. 0 seconds can also be set which turns the latching function off. This maybe of benefit when using the foot switches.

Standard using with a switch box:
 Programming mode 4. must be; Channel 2. is Std and Channel 3. is 1.

Standard using with pedals:
 Programming mode 4. must be; Channel 2. is Std and Channel 3. is 1. or 0., if user want to press the pedal continously.

SEE PAGE 28.

Radio using:
 Disconnect the switch box! Programming mode 4. must be; Channel 2. is IN and Channel 3. is 0.

- Start, green button (I) is Power on
- Stop, red button (O) is Power off
- Arrow up (1.) Push once is feed in and push second time stop the feed function
- Arrow down (2.) is reverse

HF260-EM

When the feed rollers forward is on it will only be turned off by any of the following:

1. NORMAL 'NO STRESS' OPERATION
Feed rollers forward will be turned back on automatically providing the speed is greater than the 'No Stress' speed + resume percentage.
2. OPERATION OF THE FORWARD OR REVERSE SWITCH
Feed rollers forward will be turned back with the rotary/foot switch providing the speed is greater than the 'No Stress' speed + resume percentage.
3. OPERATION OF THE SAFETY SWITCH
When the safety switch is closed again the feed rollers forward will be turned back with the rotary/foot switch providing the speed is greater than the 'No Stress' speed + resume percentage.
4. OPERATION OF THE STOP BUTTON ON THE WIZARD
Normal operation can be resumed by pressing and holding the 'RESET' button for 5 seconds, the feed rollers forward will be turned back on with the rotary/foot switch providing the speed is greater than the 'No Stress' speed + resume percentage.

N.B. If the speed is flashing than it is below the 'no-stress' + resume percentage and so operation of the feed rollers forward is not allowed.

FACTORY DEFAULT SETTINGS:



Switch the instrument off, and hold the 3 middle buttons in, while holding them in, switch the unit back on. This will reset the instrument to its factory settings.

HF260-EM

Farmi Forest Chipper 150 Calibration Data - 29.05.12

Operating Mode		Programming mode 1	Programming mode 2	Programming mode 3	Programming mode 4	Programming mode 5
Channel 1	Normal Operation	Select channel, press and hold 'STOP' to enter	Power on whilst holding 'STOP' to enter mode. Use same key to select channel	Power on whilst holding 'RESET' for 10 seconds to enter mode. Use same key to select channel	Power on whilst holding 'SET' for 10 seconds to enter mode. Use same key to select channel	Power on whilst holding outside left button to enter mode. Use same key to select channel
	Secondary Functions		Maximum Chipper Speed Default: 4000 (RPM)			Rolls Stop Speed LO Default: 0480
Channel 2	Chipper Speed (RPM)	Resume Percentage Default: 11 (%)	Maximum recorded chipper RPM	Chipper PPR Default: 1.000 (ppr)	Inputs Default: Std	
			Minimum Speed Alarm Default: 100 (RPM)	Feed Roller Reverse Delay Default: 0.1 (Secs)	Forward Latching Default: 1 (Secs)	Rolls Stop Speed MED Default: 0680
Channel 3	No Function			Feed Roller Reverse Duration Default: 0.4 (secs)	Set Button Default: ON	
					Reverse Latching Default: 0 (Secs)	Rolls Stop Speed HI Default: 0900
Channel 4	Service Countdown (Hrs)	Service Interval Set/Reset Default: 500 (Hrs)				
	Working hours (Hrs)	Grand Total Hours (Hrs)			Grand Total Hours (programmable) (Hrs)	

HF260-EM

ALARMS

- Ser** = Service interval reached
- SAFE** = Safety switch has been pressed
- STOP** = Stop button has been pressed
- PROG** = Instrument Failure
- BAtt** = Low power supply voltage (Under 9v)

ALARM LOGIC

When there is an alarm condition the instrument will default to the appropriate channel, the display will flash and the internal buzzer will sound 5 times. The instrument will remain on this channel with the display flashing until either:

- another channel is selected and the alarm is ignored (see below)
- the alarm condition is rectified

For any of the 2 channels the internal buzzer will also sound again 5 times if the instrument remains alarming for more than 30 seconds. This will be repeated again 30 seconds later unless one of two aforementioned actions have occurred.

An alarm condition can be ignored by selecting another channel. If this is done then the display will flash when the alarming channel is re-selected. The alarm will also be repeated 30 seconds later if it hasn't been rectified.

The alarms will be prioritised as follows:

- Stop switch input (channel 2)
- Chipping speed alarm (channel 2)
- Service interval (channel 6)

Should 3 alarm conditions exist the highest priority one will be shown first, if this is then ignored the instrument should automatically then indicate the 2nd alarm.

All alarms will operate on the medium 'beep' rate and the external alarm output will not be used.

HIGH CHIPPING SPEED

The instrument will default to the chipping speed channel (channel 2), the speed will flash and the instrument will beep continuously. O/P's will be disabled.

LOW CHIPPING SPEED

The instrument will default to the chipping speed channel (channel 2), the speed will flash and the instrument will beep continuously. When the speed falls below the MINIMUM SPEED ALARM, latching is reset.

SERVICE INTERVAL REACHED

If the service interval timer (channel 5) counts down to zero then the chevron should jump to channel 5 and emit a beep and flash 'Ser'.

When the chipping unit is stopped, the chevron should jump to channel 5 and emit a beep and flash 'Ser'. If the unit is switched on and the counter is on zero then it should jump to channel 5, beep and flash 'Ser'.

The service timer can be reset by pressing and holding the RESET button.

SAFETY SWITCH ALARM

If I/P 2 is open then the display will flash 'SAFE' and O/P1 and O/P2 will be disabled until the I/P is closed.

This alarm cannot be ignored.

When the Stop Switch Alarm occurs, latching is reset.

STOP ALARM

If during normal chipping operation the 'STOP' button is pressed then all the O/P's will be disabled. This instrument will alarm and flash 'StoP' on channel 2. Normal operation can be resumed by pressing the holding the 'RESET' button for 5 seconds whilst on channel 2.

When the 'STOP' button is pressed, latching is reset. This message takes priority over the 'FR' and 'FE' messages.

PROG ALARM

If the instrument software has got damaged, such as a person welding/soldering on the machine, or a lightning strike etc. It is when the software has been corrupted.

To fix this, you switch the instrument off, hold in the 3 middle buttons and while holding them in, switch it back on. This then resets the software to how it was when it left the RDS factory (default settings).

BAtt ALARM

Low power supply voltage (Under 9v). Check the power line from the tractor.

HF260-EM

HF260 ELECTRICS

Part	Order no	Description	Remarks	Qty
1	03299520	Electrics	W150	1
1.1	03299000	Electric components		1
1.2	03299510	Control box	standard	1
1.3	03299010	Emergency stop	standard	1
1.4	03298370	W150 display		1
1.5	53298880	Vibration isolation		2
2	03299530	Pedal	accessory	1

NO STRESS FARMI 260

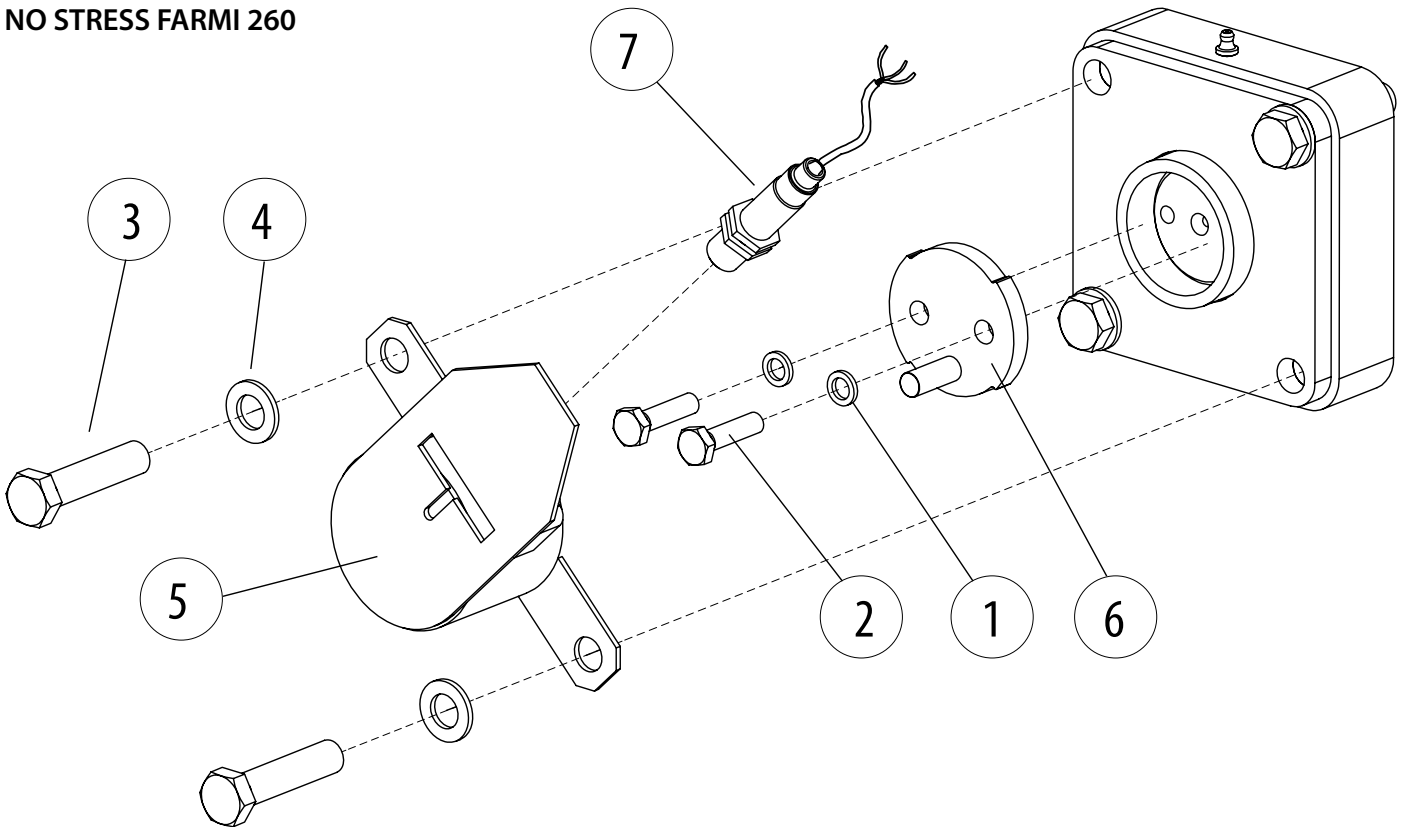

Part	Order no	Description	Remarks	Qty
1	52214251	Lock washer	M10 NORD-LOCK	2
2	52060258	Screw	M10X40 DIN933 88ZN	2
3	52062148	Screw	M16X70 DIN931 88ZN	4
4	52200078	Washer	M16 DIN126 58ZN	4
5	33296290	Splined shaft cover		1
6	43563080	Flange		1
7	55121440	Sensor		1

HF260-EM

03485100 FEED ROLLER BOTTOM

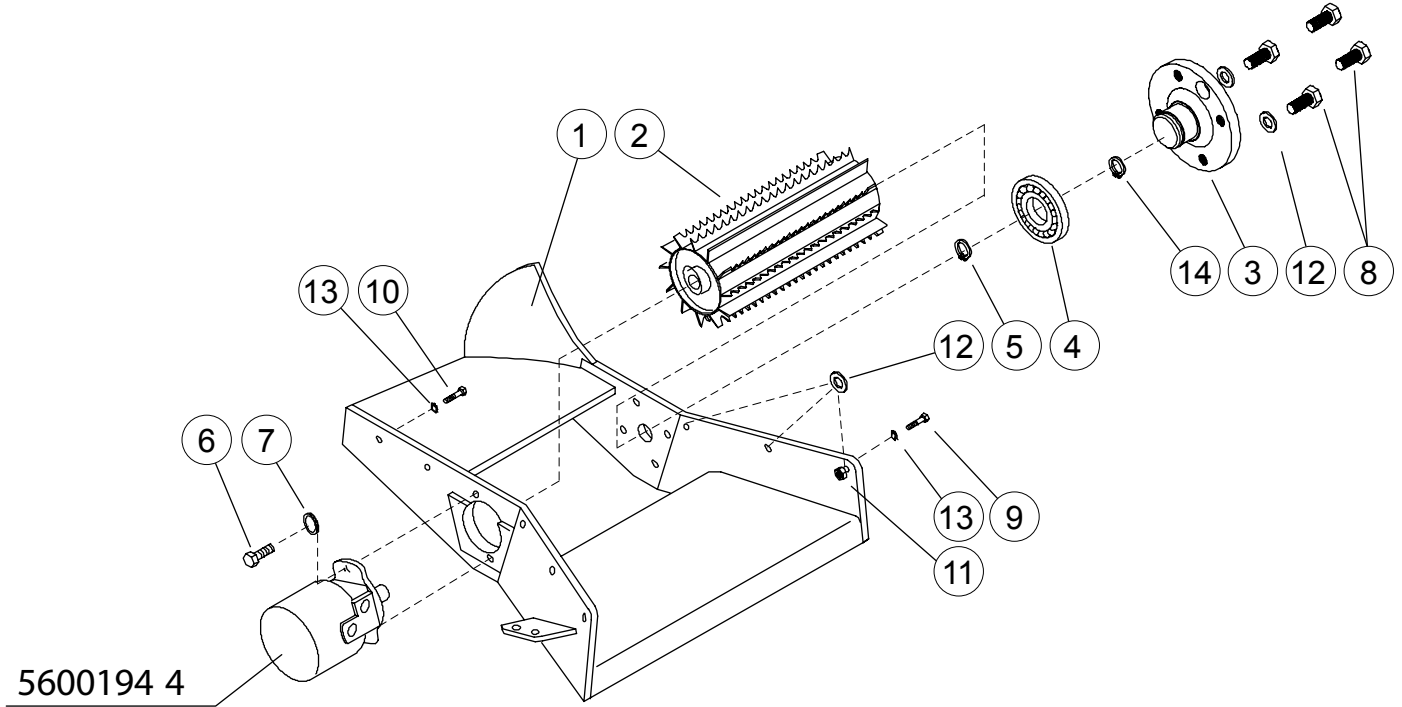

Part	Order no	Description	Remarks	Qty
1	43481280	Roller frame		1
2	43481330	Feeder roll		1
3	43313048	Fastening flange		1
4	54511340	Slotted sealed ball bearing		1
5	52230067	Circlip	35X2,5 DIN471	1
6	52090552	Screw	M12X30 DIN933 10.9	2
7	52214269	Lock washer	M12 NORD-LOCK	2
8	52060514	Screw	M10X20 DIN933 88ZN	4
9	52004199	Hexagonal socket head screw	M12x30 DIN7991 10.9	6
10	52062015	Screw	M12X20 DIN933 88ZN	4
11	52117124	Lock nut	M12 DIN985 8ZN	6
12	52211042	Spring washer	M10 DIN127 ZN	2
13	52211059	Spring washer	M12 DIN127 ZN	6
14	52231172	Circlip	72x2,5 DIN472	1

HF260-EM

03489150 FRAME, ROLLER, ROLLER'S SWING

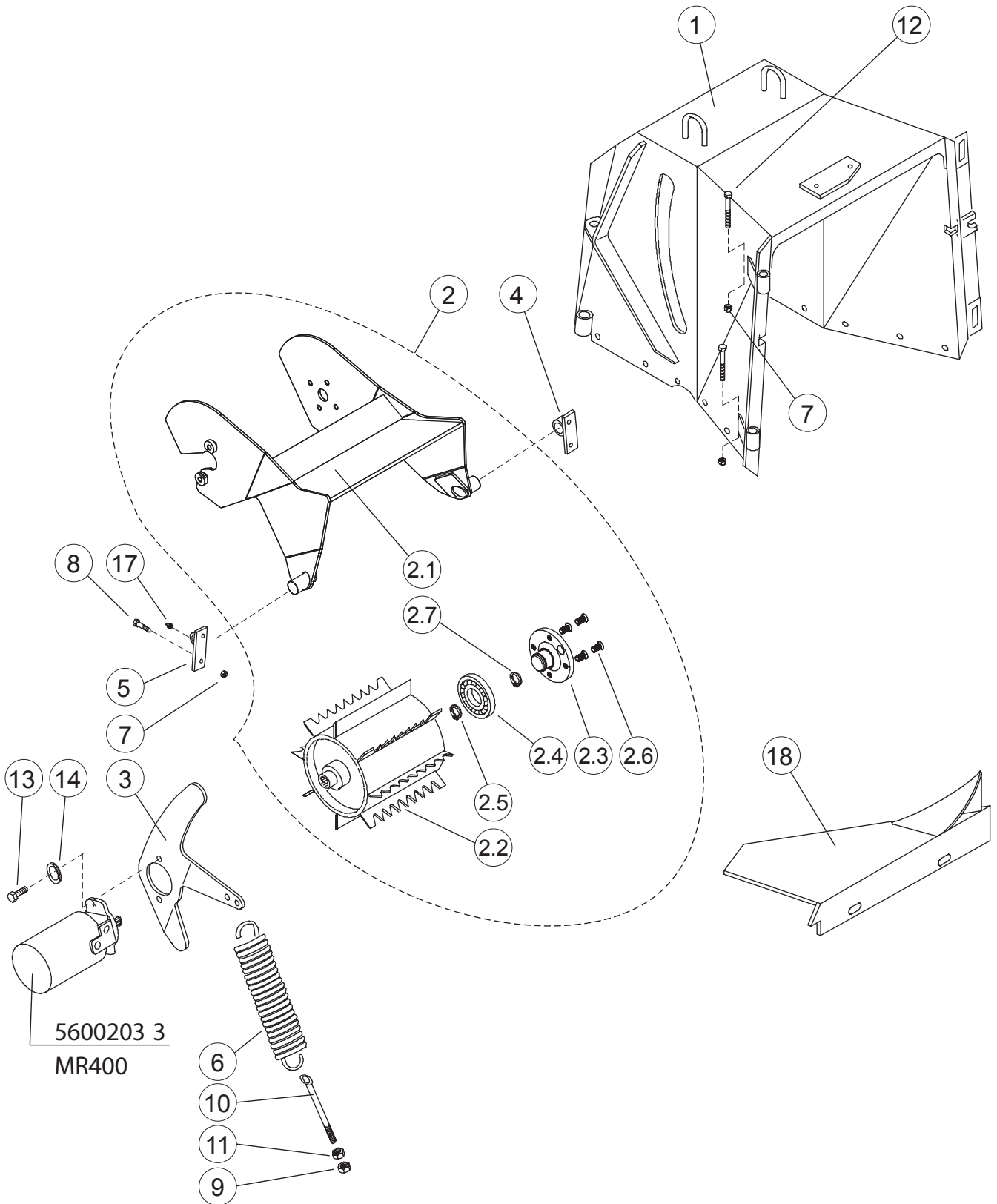

HF260-EM

03489150 FRAME, ROLLER, ROLLER'S SWING

Part	Order no	Description	Remarks	Qty
1	43489120	Frame		1
2	03484200	Roller's swing	complete	1
2.1	200000885	Roller's swing		1
2.2	43484180	Feeder roll		1
2.3	43313048	Fastening flange		1
2.4	54511340	Slotted sealed ball bearing		1
2.5	52230067	Circlip	35X2,5 DIN471	1
2.6	58211570	Hexagonal socket head screw	M10x16 DIN7991 ZN	4
2.7	52231172	Circlip	72x2,5 DIN472	1
3	43481190	Motor's fastening flange		1
4	43481440	Hinge	right	1
5	43481430	Hinge	left	1
6	94617073	Tension spring	DU68	1
7	52117108	Lock nut	M10 DIN985 8ZN	6
8	52060233	Screw	M10X30 DIN933 88ZN	4
9	52117124	Lock nut	M12 DIN985 8ZN	1
10	52062840	Eyebolt	M12X120 8.8ZN	1
11	52110293	Nut	M12 DIN934	1
12	52062850	Screw	M10X150 DIN931 88ZN	2
13	52063617	Screw	M12X40 DIN933 10.9	2
14	52214269	Lock washer	M12 NORD-LOCK	2
15	-			
16	-			
17	52401023	Grease nipple	AM6	2
18	43481850	Adaptor piece		1
19	43488410	Support for transportation		1

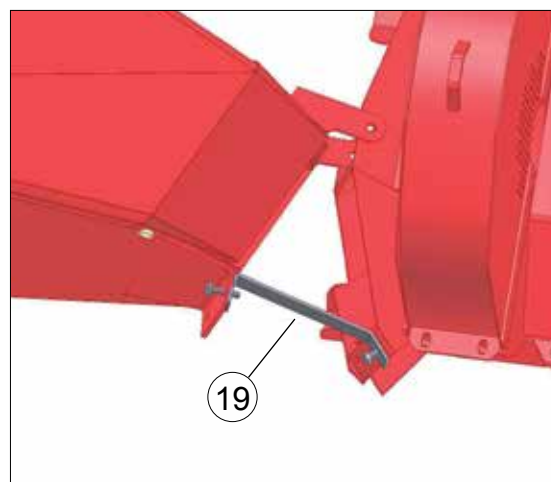

HF260-EM

03489210 FEED CHUTE HF260-EM

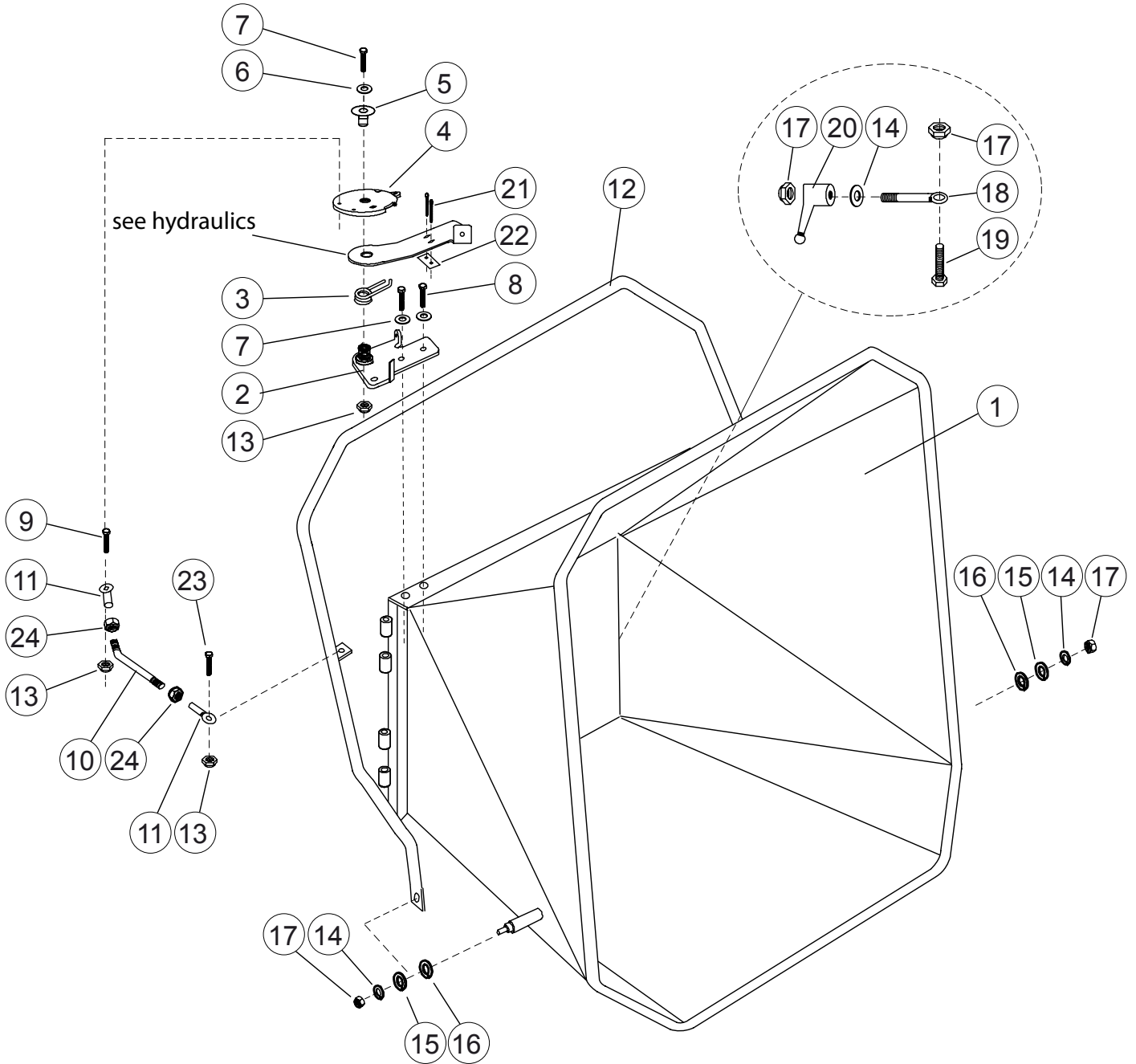

HF260-EM

03489210 FEED CHUTE HF260-EM

Part	Order no	Description	Remarks	Qty
1	43488000	Feed chute		1
2	43487970	Fastener		1
3	43482730	Torsion spring	DU36 DL5,5	1
4	43488340	Wafer		1
5	43482840	Flanged bush	D40X13	1
6	52211042	Spring washer	M10 DIN127 ZN	3
7	52060944	Screw	M10X60 DIN933 88ZN	1
8	52060209	Screw	M10X16 DIN933 88ZN	2
9	52060258	Screw	M10X40 DIN933 88ZN	1
10	43488660	Lever		1
11	54591140	Clevis pin		2
12	43488220	Stop handle		1
13	52117108	Lock nut	M10 DIN985 8ZN	3
14	52200466	Washer	M12 DIN440 ZN	3
15	43483680	Rubber		2
16	52200078	Washer	M16 DIN126 58ZN	2
17	52117124	Lock nut	M12 DIN985 8ZN	4
18	52062840	Eyebolt	M12X120 88ZN	1
19	52062031	Screw	M12X40 DIN933 88ZN	1
20	43489820	Hand level		1
21	52030350	Screw	M4X40 DIN7985 58ZN	2
22	43488490	Counter part		1
23	52060233	Screw	M10X30 DIN933 88ZN	1
24	52110046	Nut	M10 DIN934 8ZN	2

HF260-EM

200003108 FEED CHUTE EXTENSION

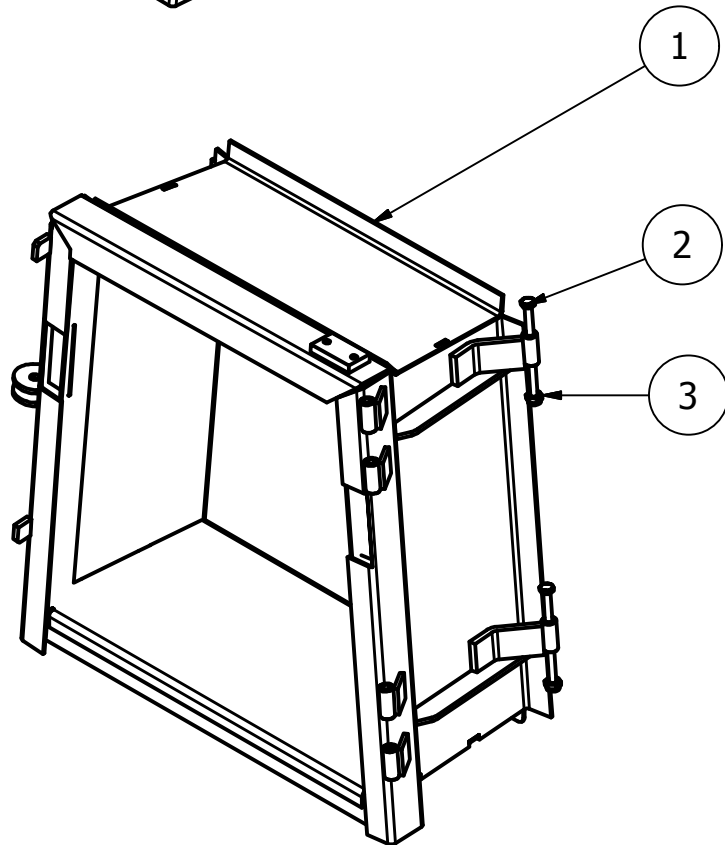
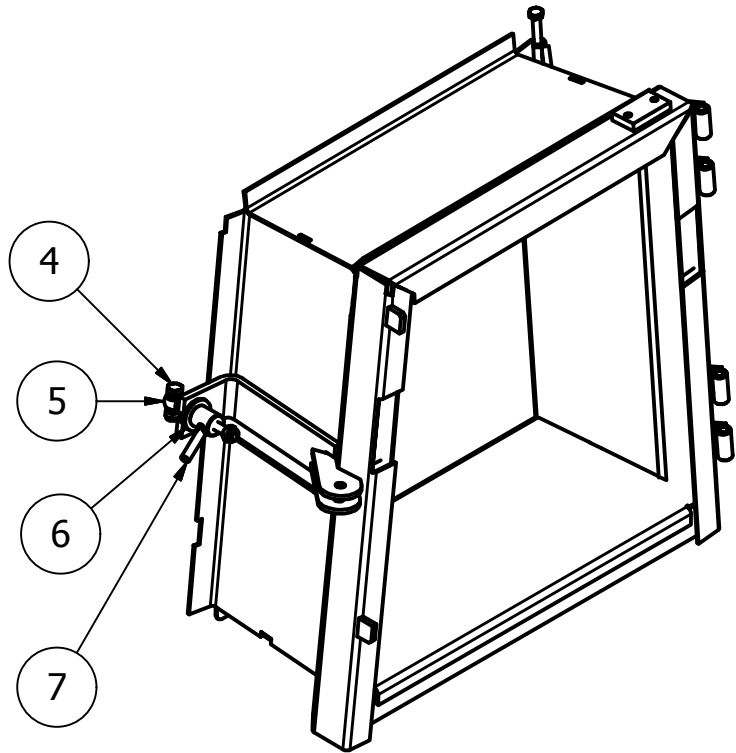

HF260-EM

200003108 FEED CHUTE EXTENSION

Part	Order no	Description	Remarks	Qty
1	200003101	Extension		1
2	52062850	Hex screw	ST8.8ZN, M10X150, DIN931	2
3	52117124	Lock nut	ST8.8ZN, M12, DIN985	4
4	52062031	Hex screw	ST8.8ZN, M12X40, DIN933	1
5	52062840	Eye screw	ST8.8ZN, M12X120, DIN444	1
6	52200466	Washer	ZN, M12, DIN440	1
7	43489820	Lever		1

HF260-EM

03489160 HYDRAULICS

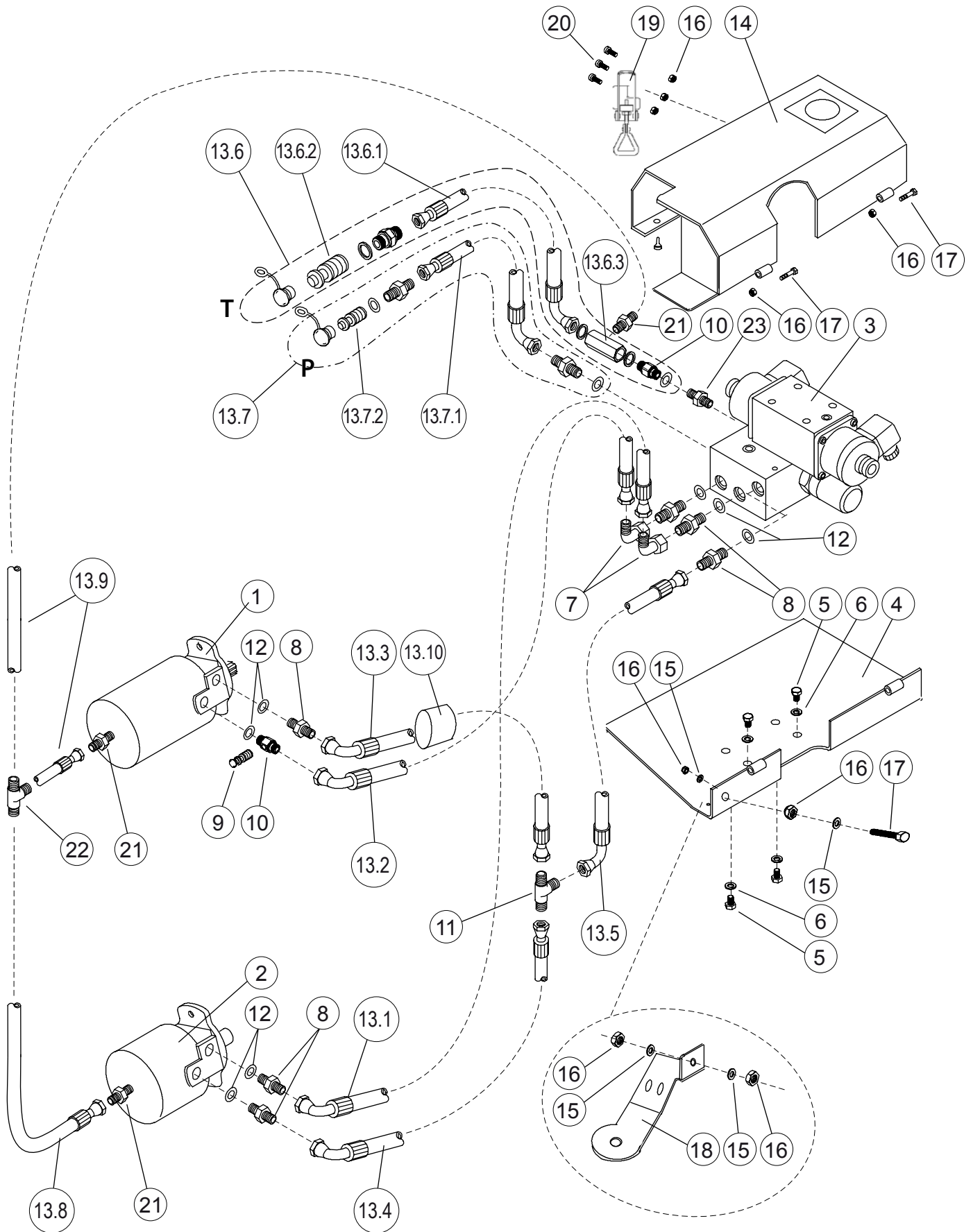

HF260-EM

03489160 HYDRAULICS

Part	Order no	Description	Remarks	Qty
1	56002033	Hydraulic motor		1
1.1	58217640	Seal kit	for M+S Hydraulic motor	1
	OR			
1.1	58218827	Seal kit	for Danfoss motor	1
2	56001944	Hydraulic motor		1
2.1	58217746	Seal kit	for M+S Hydraulic motor	1
	OR			
2.1	52357589	Seal kit	for Danfoss motor	1
3	56072119	Control valve	Vickers	1
4	43488430	Valve bottom plate		1
5	52060209	Screw	M10X16 DIN933 88ZN	4
6	52211042	Spring washer	M10 DIN127 ZN	4
7	52442175	Angle nipple	R1/2, 90o	2
8	52432051	Double fitting	R1/2	6
9	52449162	Measuring point		1
10	52435815	Gauge fitting	R1/2-R1/2-R1/4	2
11	52443686	T-nipple	R1/2	1
12	52390200	Usit-ring	U21,54X28,58X2,49	7
13	03482540	Hose series		1
13.1	56525165	Hose assy	V1/2"S L=1,1 m	1
13.2	56525132	Hose assy	V1/2"S L=0,9 m	1
13.3	56525074	Hose assy	V1/2"S L=0,6 m	1
13.4	56525033	Hose assy	V1/2"S L=0,4 m	1
13.5	56526049	Hose assy	K1/2"S L=0,45 m	1
13.6	03484370	Hose assy		1
13.6.1	56526270	Hose assy	K1/2"S L=2,2 m	1
13.6.2	52449022	Quick fitting	1/2"	1
13.6.3	56013246	Back pressure valve	1/2", arrow to tank	1
13.7	03484380	Hose assy		1
13.7.1	56526270	Hose assy	K1/2"S L=2,2 m	1
13.7.2	52449022	Quick fitting	1/2"	1
13.8	56517089	Hose assy	V1/4"S L=0,65 m	1
13.9	56518061	Hose assy	K1/4"S L=0,55 m	2
13.10	54921473	Water drainage pipe		7
14	43488450	Valve cover		1
15	52200029	Washer	M6 DIN126 58ZN	4
16	52117066	Lock nut	M6 DIN985 8ZN	8
17	52060068	Screw	M6X50 DIN933 88ZN	3
18	43488350	Fastening plate		1
19	54712020	Latch		1
20	52091816	Hexagon socket countersunk head cap screw	M6X16 DIN7991	3
21	52432101	Double fitting	R1/4"	3
22	52443660	T-nipple	R1/4"	1
23	52435773	Swivel fitting	R1/2"	1

HF260-EM

HYDRAULICS CIRCUIT DIAGRAM

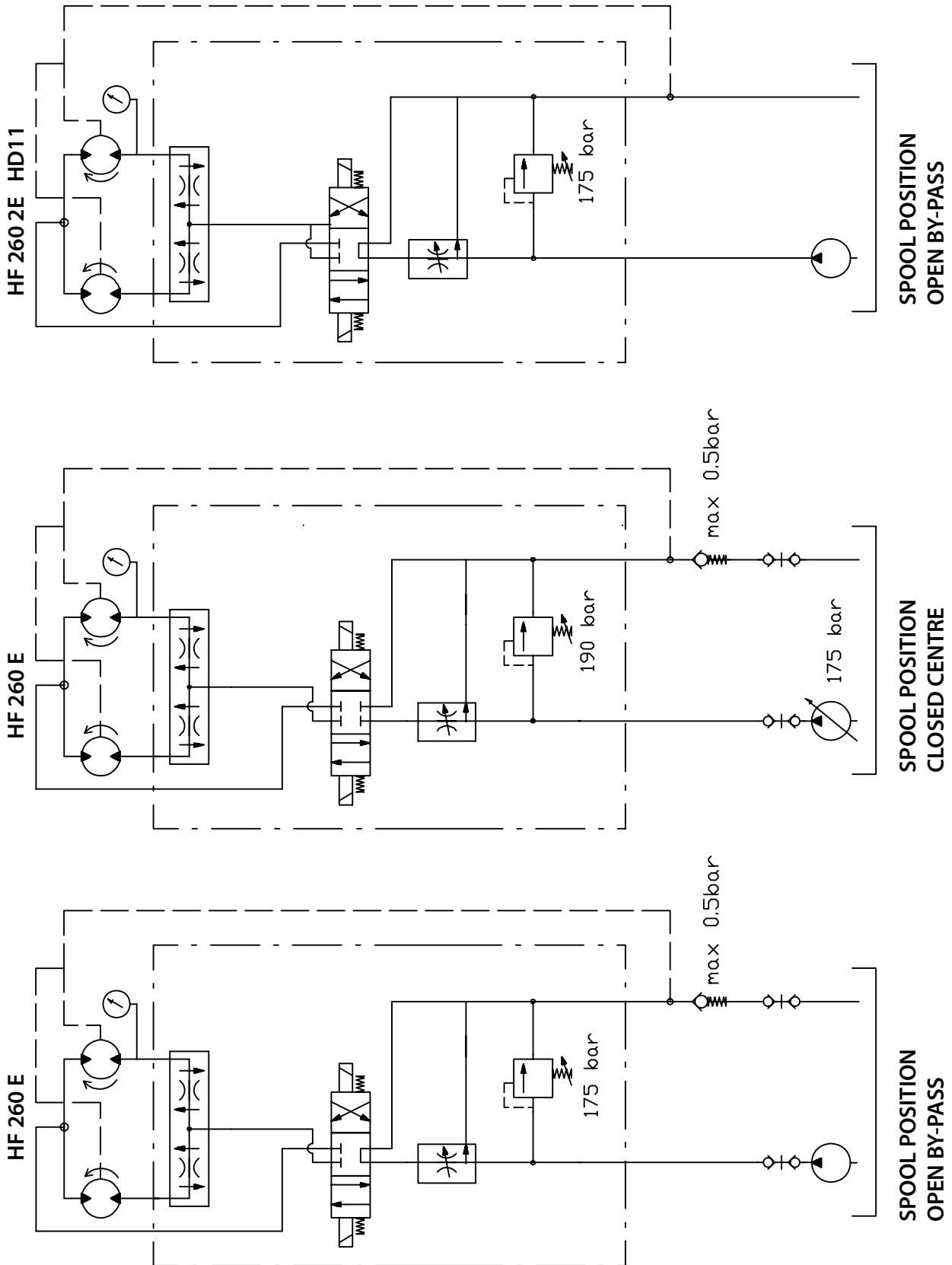

HF260-EM

56072119 DIRECTIONAL CONTROL VALVE VICKERS

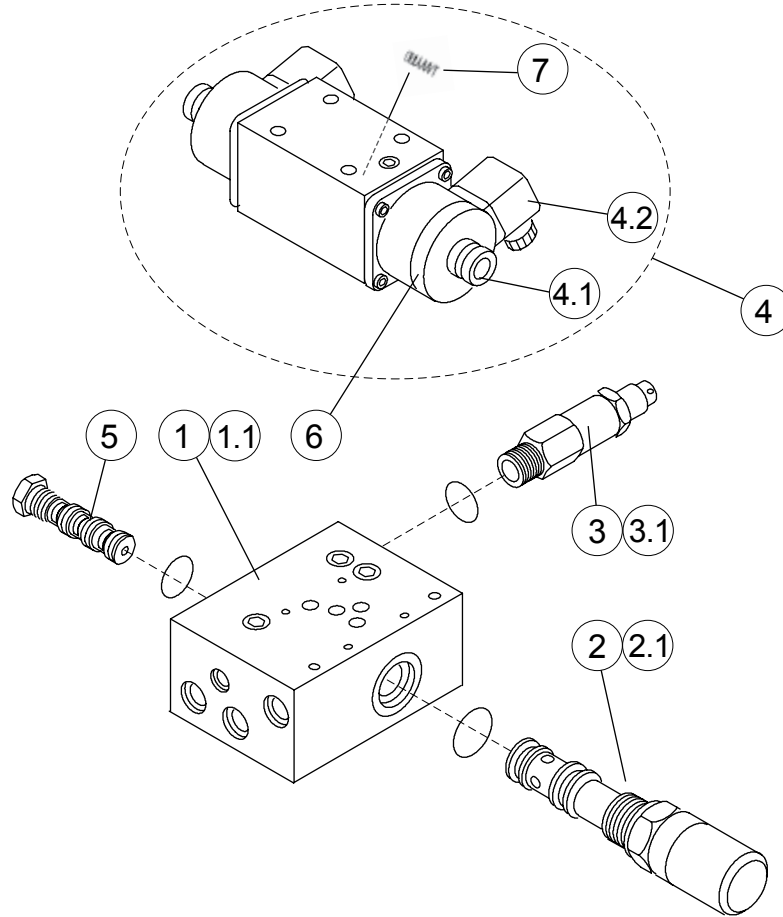

Part	Order no	Description	Remarks	Qty
1	23482051	Valve block		1
1.1	58104810	Seal kit		1
2	58104696	Flow regulator valve		1
2.1	58104800	Seal kit		1
3	58104704	Pressure relief valve	175 bar	1
3.1	58104790	Seal kit		1
4	56057243	Electric control valve		1
4.1	56057230	Solenoid spool		2
4.2		Connector		2
5	58213596	Flow divider valve		1
6	56057270	Nut		2
7	58103640	Spring		2

WARRANTY

Farmi Forest Oy grants a 12-month warranty on all of its products, covering material and manufacturing faults. The warranty comes into effect on the product's delivery date.

The manufacturer is not liable for damages caused by:

- misuse of the product
- alterations or repairs made without the manufacturer's permission
- insufficient maintenance
- non-original parts

The warranty does not cover wearing parts.

Send faulty parts, carriage paid, to the manufacturer for inspection. Repairs will be conducted by Farmi Forest Oy or an authorized expert. The warranty is valid only if the bottom part of this page is filled in and returned to the manufacturer within 30 days of receipt of the product.

By returning the warranty certificate, you confirm that you have read and understood the instruction manual that came with the product.



FARMI[®]
FOREST

Farmi Forest Corporation
Ahmolantie 6
FIN-74510 IISALMI
FINLAND

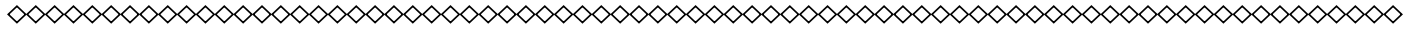

PRODUCT REGISTRATION FORM

Date of delivery: ____/____ 20____

Dealer:

Dealer's address:

Dealer's tel:

Product and type:

Serial number:

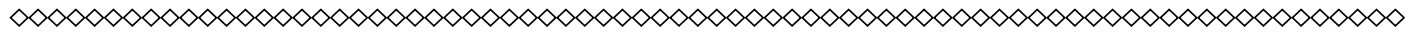

Return to the manufacturer

Date of delivery: ____/____ 20____

Dealer:

Dealer's address:

Dealer's tel:

Customer:

Customer's address:

Customer's tel:

E-mail address:

Product and type:

Serial number:





Farmi Forest Corporation
Ahmolantie 6
FIN-74510 Iisalmi, Finland
Puh. +358 (0)17 83 241
Fax. +358 (0)17 8324 372
www.farmiforest.fi