

STAMA PRODUCT CATALOGUE



STAMA

The STAMA range of products include Leaf Collector MK8, Micro EL, Parker EL, Mini EL, Multi EL, Evo EL and Maxi EL.

As we wish to protect the environment, STAMA trucks are built with electric motors. Electric motors render the trucks almost silent and at the same time emission-free operation.

The STAMA product line is a modern range of multifunctional vehicles, all built for operation by professional users who require high performance, build quality and reliability.

All trucks come standard with electric parking brake, adjustable speed, digital multi-functional display showing battery capacity and speed.

Leaf Collector MK8



Leaf collector MK8..... Page 3

Micro EL Page 4

Parker EL..... Page 5

Mini EL..... Page 6

Multi EL..... Page 7

Evo EL Page 8

Maxi 4WD EL..... Page 9

Extra equipment Page 10-11

NOTE: The images in this brochure are often shown with optional extras

Icon explanation:

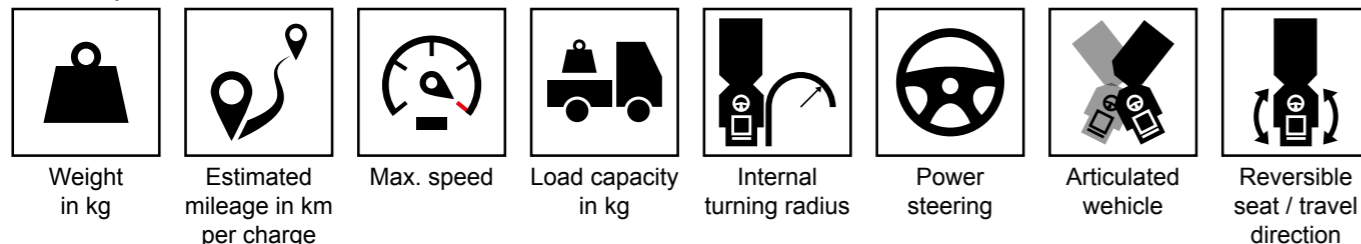

- 24V 800W DC electric engine
- Powerful suction unit with 13 hp B&S Vanguard engine with electrical start
- Progressive speed control
- Adjustable hose rack
- Reversible control handle
- Hour Metre
- 4 wheeled with low centre of gravity which ensures good stability
- Self-charging batteries when using the suction unit

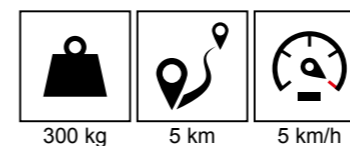

Micro EL



- 105 Ah maintenance-free gel batteries
- Maintenance-free lithium-ion batteries (optional)
- 24V 1,7 kW AC electrical motor
- Manual dump body - 900 x 1000 mm
- Easy access
- Tight turning circle

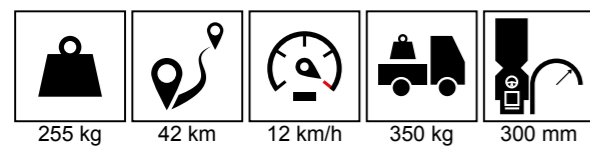
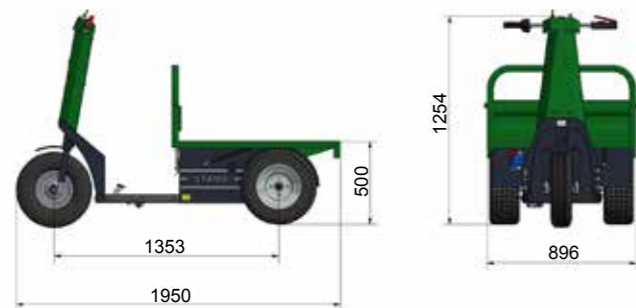

Parker EL



- 180 Ah maintenance-free gel batteries
- 24V 1,7 kW AC electrical motor
- Manual 3-way dump body - 900 x 1400 mm
- Low loading height
- Tight turning circle
- Adjustable sprung seat
- Easy access
- 2-speed drive

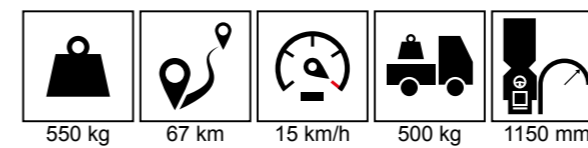

Mini EL - Articulated with reversible driver platform



- 180 Ah Lead acid batteries
- Maintenance-free lithium-ion batteries (optional)
- 24V 1,7 kW AC electrical motor
- Hydraulic dump body - 900 x 1400 mm (optional with manual turntable)
- Adjustable steering wheel and driver's seat
- Easy access
- Tight turning circle
- 2-speed drive

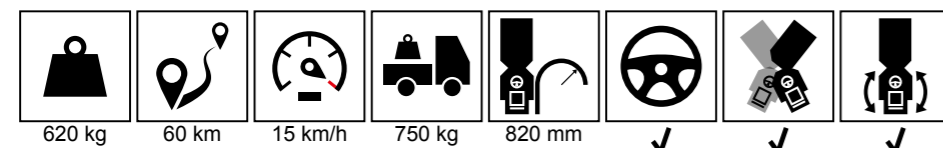

Multi EL



- 180 Ah Lead acid batteries
- Maintenance-free lithium-ion batteries (optional)
- 48V 4 kW AC electrical motor
- Hydraulic dump body with hydraulic turntable -1000 x 1500 mm
- Low loading height
- Adjustable steering wheel and driver's seat
- Suspended front axle and 2-speed drive

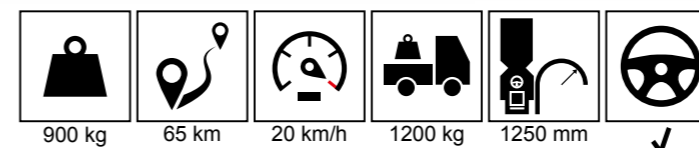

Evo EL



- 240 Ah Lead acid batteries
- Maintenance-free lithium-ion batteries (optional)
- 48V 6,5 kW AC electrical motor
- Hydraulic dump body with hydraulic turntable - 1100 x 1800 mm
- Low loading height
- Easy access
- Suspended front axle

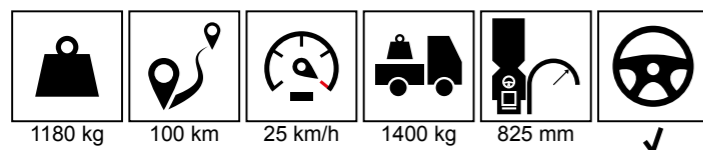

Maxi EL - Articulated with reversible driver platform



- 240 Ah Lead acid batteries
- Maintenance-free lithium-ion batteries (optional)
- 2 x 48V electric motors of each 4 kW
- Hydraulic dump body - 1000 x 1500 mm (optional with hydraulic turntable)
- Adjustable steering column and sprung seat
- Easy access
- 4 wheel drive (4 WD)
- 2-speed drive

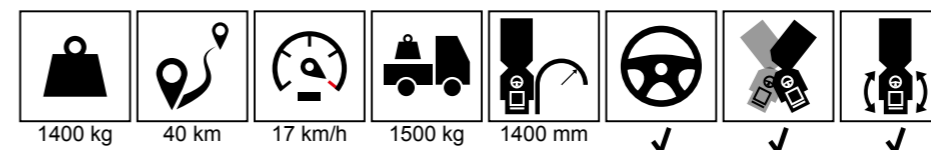
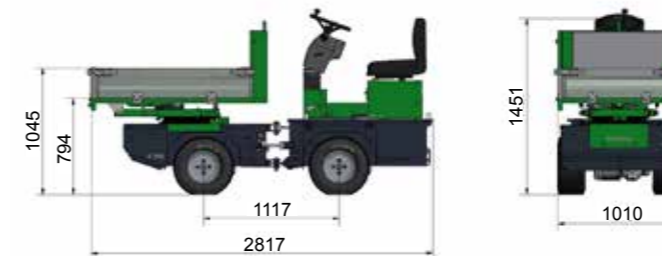

Extra equipment

TECHNICAL DATA	Micro	Parker	Mini	Multi	Evo	Maxi
Battery:						
Gel batteries without internal charger, 105 Ah	s					
Gel batteries incl. external charger, 180 Ah		s				
Lead acid batteries incl. external charger, 180 Ah			s			
Lead acid batteries incl. internal charger, 180 Ah				s		s
Lead acid batteries incl. internal charger, 240 Ah					s	
Lead acid batteries without external charger, 320 Ah					x	
Lithium batteries incl. internal charger, 130 Ah	x		x	x		x
Lithium batteries incl. internal charger, 250 Ah					x	
Water container for lead acid batteries				x	x	x
Body:						
Dump body without body sides (900 x 1000 x 250 mm)	s					
Long body without body sides (900 x 1200 x 250 mm)	x					
Body with 3-way-dump and hinged body sides (900 x 1400 x 250 mm)		s				
Hydraulic dump body incl. hinged body sides (900 x 1400 x 250 mm)			s			
Hydraulic dump body incl. Hinged body sides (1000 x 1500 x 250 mm)						s
Hydraulic dump body w. manuel turntable, incl. hinged body sides (900 x 1400 x 250 mm)			x			
Hydraulic dump body w. hydraulic turntable, incl. hinged body sides (1000 x 1500 x 250 mm)				s		x
Hydraulic dump body w. hydraulic turntable, incl. hinged body sides (1100 x 1800 x 300 mm)					s	
Hydraulic dump body w. hydraulic turntable, incl. hinged body sides (1300 x 1800 x 300 mm)					x	
Hydraulic dump body with firm sides (1000 x 1500 x 540 mm)						x
Body:						
Hinged body sides (250 mm / Evo 300 mm)	x	s	s	s	s	s
Tall body sides (250 mm)		x	x	x		x
Tall body sides - with top hung tail (250 mm)			x	x		x
Leaf sides (500 mm)	x		x	x	x	x
Body extension - flat (250 mm)	x	x	x	x		x
Body extension - 20° slope (250 mm)	x	x	x	x		x
Tool rack, large	x					
Tool rack, small	x					
Flower shelf each	x					
Tool carrier	x					
Bucket support	x					
Garbage support	x					

S = Standard
X = Optional extras

Extra equipment

TECHNICAL DATA	Micro	Parker	Mini	Multi	Evo	Maxi
Optional:						
Convertor 230V / 1200W				x	x	
Set of armrest			x	x	x	s
Padded seat / back support	x					
Extra seat				x	x	
Bed seat				x		
Seatbelt			x	x	x	x
Cap with washer and wiper (no doors and rear window)				x	x	
Doors for cap				x	x	
Electrical heating for cap				x	x	
Hitch	x	x	x	x	x	x
13 pole 12V socket for trailer					x	
7 pole 12V socket for trailer				x	x	
Agricultural tyres, 4 pcs.						x
Rake 120 or 104 cm - double, with changeable spring tines		x	x	x		x
12V outlet for rake			x			
Complete counterweight, rear 1 pcs. 173 kg (for units with li-ion batteries only)						x
Complete counterweight, front 2 pcs. 62 kg each						x
Complete counteweight, 1 pcs. 60 kg			x			
Watering system:				On request		
1000 L fiberglass tank with 5 m hose and hand shower and sprinkler					x	
Automatic hose reels incl. couplings and fittings and 30 m 3/4" hose					x	
Automatic hose reels for A-frame cat. 0, incl. 30 m 3/4" hose					x	
Electric integrated water pump 1-speed control					x	
Water pump control 4-step control					x	
Hydraulic:						
Hydraulic outlet, single (front)			x			
Double hydraulic outlet (front)			x	x	x	x
Double hydraulic outlet (rear)				x		
Hydraulic rear lift		x		x		
Hydraulic lift cat. 0 (front)			x	x	x	x
Lights:						
Daytime running lights front and rear	x	x	x	s	s	x
Complete set of lights - postion-, back- and brake light	x	x	x	x	x	x
Warning flash				x	x	
Rotating beacon (for cab only)					x	

TECHNICAL DATA	MK-8
Flexible suction hose 6 m Ø 6" with lightweight control handle	s
Plastic hose storage	s
Spout, 65 cm	x
Washable set of filters	x
Narrow wheelset and modification parts reducing the width to 72 cm	x
Extra bag	x

S = Standard
X = Optional extras

GMR MASKINER A/S IS ALSO...

- SWEEPERS
- GRASS EQUIPMENT
- SNOW REMOVING EQUIPMENT
- HEDGE AND TREE CUTTERS
- ENVIROMENT MACHINES



Saturnvej 17
DK-8700 Horsens
www.gmr.dk

Dealer:



MELIT AP
KOMMUNAAL- JA METSATEHNIKA

www.melit.ee tel/fax: +372 6384 336
info@melit.ee mob: +372 55546297